



# TEST CERTIFICATES IN HOUSE



# QUALITY CONTROL PROCESS

## **PRE-PRODUCTION INSPECTION**

Drawing Check  
Specific Conditions Check

## **HEADING / THREADING / PINCH POINTING**

Machinery Condition Check  
Molds and Dies Inspection and Setup

## **HEAT TREATMENT**

Strictly controlled process  
Fully equipped with well maintained case depth and hardness testers

## **SURFACE TREATMENT**

Well equipped with salt-spray and corrosion test machinery

## **PRE-SHIPMENT INSPECTION**

Manual Sorting and Rearrangement  
Optical Sorting (Optional)

## **FINAL INSPECTION**

Dimension  
Functionality  
Aesthetics

**PRE-SHIPMENT SAMPLES SENT UPON REQUEST**



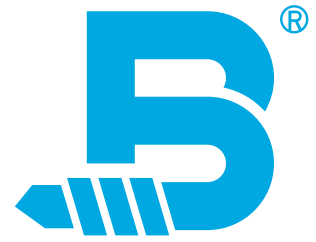



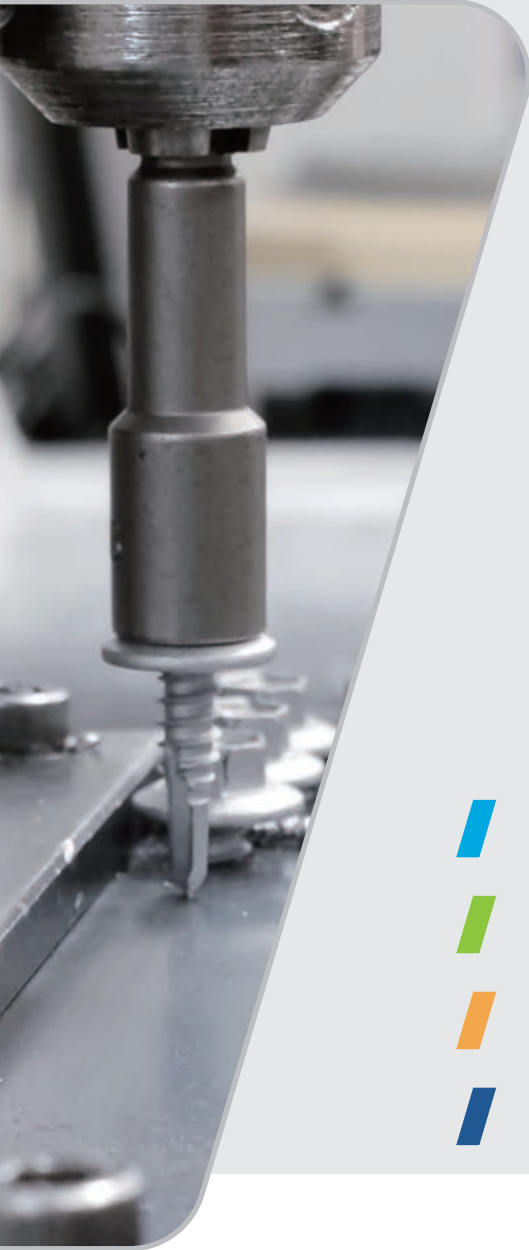

**BDN** FASTENERS



## CONTENT

	<b>METAL-Tite™ Self-Drilling Screws</b>	_____	<b>01-24</b>
	<b>Framing Fasteners</b>	_____	<b>25-27</b>
	<b>TIMBER-Tite™ Self-Tapping Screws</b>	_____	<b>28-31</b>
	<b>Collated Drywall Screw</b>	_____	<b>32-34</b>

Phone: +886-7-6282702  
Fax: +886-7-6282602  
Email: info@broadenal.com.tw



Customer		Insp Cert No.	
P/O No.		Insp Cert Date	2023/2/17
Part No.	BN3-SDHC1016C3N	Batch No.	
Description	10-16 x 16mm, Hex Flange Head Self-drilling Screw, Dual-Edge Point, Silver Grey Ruspert 1000hrs, Green Line EPDM Washer, Head Mark: BN3, Drawing: BN3-SDHC1016C3		

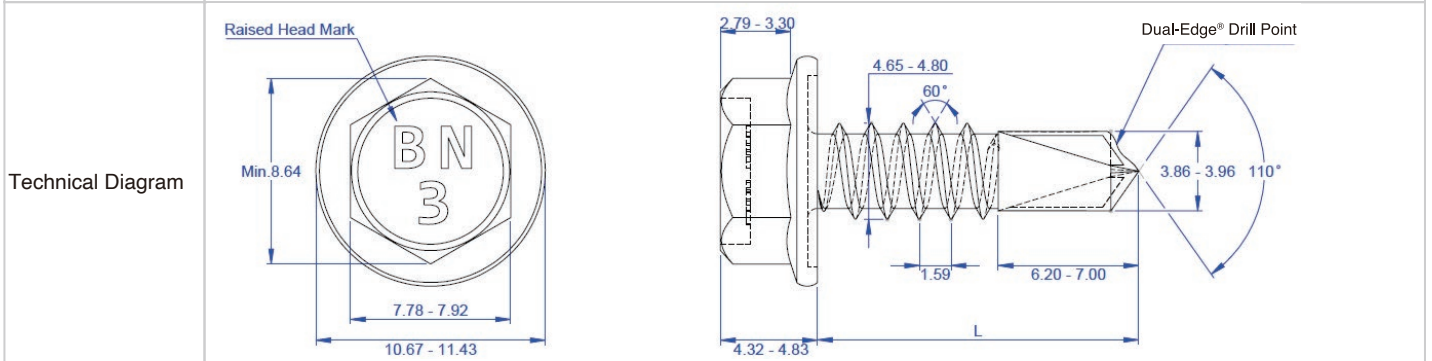

No	Inspect Item	Standard	Unit	Measured											
				1	2	3	4	5	6	7	8	9	10		
1	Across Corner	min 8.64	mm	8.94	8.97	8.86	8.92	8.93							
2	Across Flat	7.78-7.92	mm	7.81	7.82	7.92	7.82	7.83							
3	Washer Diameter	10.67-11.43	mm	10.85	11.11	10.89	11.07	10.92							
4	Total Head Height	4.32-4.83	mm	4.47	4.48	4.46	4.43	4.50							
5	Total Length	15.20-16.00	mm	15.43	15.55	15.53	15.51	15.47							
6	Major Diameter	4.65-4.80	mm	4.66	4.67	4.67	4.68	4.68							
7	Pitch	1.59	mm	1.59	1.59	1.59	1.59	1.59							
8	Drill Point Length	6.20-7.00	mm	6.53	6.55	6.34	6.58	6.41							
9	Drill Point Width	3.86-3.96	mm	3.90	3.92	3.93	3.93	3.94							
10	Outer Diameter(EPDM)	9.20-9.80	mm	9.32	9.55	9.39	9.45	9.40							
11	EPDM Thickness	2.40-3.00	mm	2.44	2.46	2.43	2.44	2.45							
12	Surface Hardness(HV)	min 560	HV	605.00	609.00	606.00	609.00	607.00							
13	Core Hardness(HV)	max 425	HV	414.00	417.00	410.00	416.00	413.00							
14	Torsional Strength(N.m)	min 6.9	N.m	7.93	8.48	8.56	9.01	8.14							
15	Drilling Test 1 (27kg 2500rpm 4.5mm)	max 5.0	Sec	2.44	2.73	2.86	2.72	2.56	2.68	2.60	2.69	2.81	2.17		

Inspection Results	<b>OK</b>	Inspected	00096	Approved	
		Date	2023/2/17	Date	

Phone: +886-7-6282702  
Fax: +886-7-6282602  
Email: info@broadenal.com.tw



Customer		Insp Cert No.	
P/O No.		Insp Cert Date	2023/1/16
Part No.	BN3-SDHC1019C3N	Batch No.	
Description	10-16 x 19mm, Hex Flange Head Self-drilling Screw, Dual-Edge Point, Silver Grey Ruspert 1000hrs, Green Line EPDM Washer, Head Mark: BN3, Drawing: BN3-SDHC1019C3		
Technical Diagram			

No	Inspect Item	Standard	Unit	Measured											
				1	2	3	4	5	6	7	8	9	10		
1	Across Corner	min 8.64	mm	8.96	8.98	8.99	8.95	8.97							
2	Across Flat	7.78-7.92	mm	7.83	7.83	7.84	7.85	7.84							
3	Washer Diameter	10.67-11.43	mm	11.02	11.08	11.03	11.04	11.05							
4	Total Head Height	4.32-4.83	mm	4.62	4.61	4.66	4.61	4.63							
5	Total Length	19.00-19.80	mm	19.68	19.60	19.44	19.60	19.67							
6	Major Diameter	4.65-4.80	mm	4.72	4.73	4.71	4.73	4.74							
7	Pitch	1.59	mm	1.61	1.61	1.61	1.61	1.61							
8	Drill Point Length	6.20-7.00	mm	6.59	6.33	6.60	6.54	6.38							
9	Drill Point Width	3.86-3.96	mm	3.93	3.95	3.95	3.93	3.94							
10	Outer Diameter(EPDM)	9.20-9.80	mm	9.47	9.52	9.56	9.53	9.55							
11	EPDM Thickness	2.40-3.00	mm	2.53	2.49	2.47	2.47	2.51							
12	Surface Hardness(HV)	min 560	HV	598.00	603.00	607.00	613.00	599.00							
13	Core Hardness(HV)	max 425	HV	411.00	408.00	413.00	409.00	414.00							
14	Torsional Strength(N.m)	min 6.9	N.m	9.90	10.10	9.60	9.80	9.80							
15	Drilling Test 1 (27kg 2500rpm 4.5mm)	max 5.0	Sec	2.27	2.18	2.47	2.23	2.79	2.32	2.64	2.08	2.50	2.70		

Inspection Results	<b>OK</b>
--------------------	-----------

Inspected	00075	Approved	
Date	2023/1/16	Date	

Phone: +886-7-6282702  
Fax: +886-7-6282602  
Email: info@broadenal.com.tw



Customer		Insp Cert No.	
P/O No.		Insp Cert Date	2023/2/17
Part No.	BN3-SDHC1025C3N	Batch No.	
Description	10-16 x 25mm, Hex Flange Head Self-drilling Screw, Dual-Edge Point, Silver Grey Ruspert 1000hrs, Green Line EPDM Washer, Head Mark: BN3, Drawing: BN3-SDHC1025C3		
Technical Diagram			

No	Inspect Item	Standard	Unit	Measured											
				1	2	3	4	5	6	7	8	9	10		
1	Across Corner	min 8.64	mm	8.88	8.93	8.96	8.99	8.98							
2	Across Flat	7.78-7.92	mm	7.85	7.80	7.81	7.82	7.82							
3	Washer Diameter	10.67-11.43	mm	11.04	11.13	11.18	11.12	11.09							
4	Total Head Height	4.32-4.83	mm	4.70	4.66	4.66	4.58	4.67							
5	Total Length	23.80-25.00	mm	24.43	24.64	24.77	24.63	24.63							
6	Major Diameter	4.65-4.80	mm	4.68	4.68	4.68	4.67	4.69							
7	Pitch	1.59	mm	1.59	1.59	1.59	1.59	1.59							
8	Drill Point Length	6.20-7.00	mm	6.59	6.48	6.76	6.57	6.64							
9	Drill Point Width	3.86-3.96	mm	3.93	3.93	3.91	3.91	3.95							
10	Outer Diameter(EPDM)	9.20-9.80	mm	9.43	9.33	9.35	9.21	9.30							
11	EPDM Thickness	2.40-3.00	mm	2.51	2.52	2.46	2.42	2.54							
12	Surface Hardness(HV)	min 560	HV	617.00	613.00	615.00	619.00	616.00							
13	Core Hardness(HV)	max 425	HV	413.00	416.00	411.00	415.00	414.00							
14	Torsional Strength(N.m)	min 6.9	N.m	8.56	8.83	8.81	8.67	8.77							
15	Drilling Test 1 (27kg 2500rpm 4.5mm)	max 5.0	Sec	2.46	3.28	2.74	2.88	2.44	2.57	2.94	2.89	2.52	2.57		

Inspection Results	<b>OK</b>
--------------------	-----------

Inspected	00067	Approved	
Date	2023/2/17	Date	

Phone: +886-7-6282702  
Fax: +886-7-6282602  
Email: info@broadenal.com.tw



Customer		Insp Cert No.	
P/O No.		Insp Cert Date	2023/1/19
Part No.	BN3-SDHC1220C3N	Batch No.	
Description	12-14 x 20mm, Hex Flange Head Self-drilling Screw, Dual-Edge Point, Silver Grey Ruspert 1000hrs, Green Line EPDM Washer, Head Mark: BN3, Drawing: BN3-SDHC1220C3		
Technical Diagram			

No	Inspect Item	Standard	Unit	Measured											
				1	2	3	4	5	6	7	8	9	10		
1	Across Corner	min 8.64	mm	8.99	8.99	8.99	8.99	8.98							
2	Across Flat	7.78-7.92	mm	7.86	7.84	7.84	7.84	7.85							
3	Washer Diameter	13.97-14.78	mm	14.27	14.37	14.33	14.39	14.30							
4	Total Head Height	5.08-5.92	mm	5.77	5.80	5.79	5.81	5.77							
5	Total Length	19.20-20.80	mm	19.96	19.88	20.00	19.99	19.83							
6	Pitch	1.81	mm	1.86	1.86	1.86	1.86	1.86							
7	Major Diameter	5.28-5.46	mm	5.36	5.37	5.34	5.36	5.35							
8	Drill Point Length	7.00-8.00	mm	7.85	7.77	7.71	7.48	7.63							
9	Drill Point Width	4.50-4.60	mm	4.58	4.58	4.58	4.60	4.59							
10	Outer Diameter(EPDM)	10.70-11.30	mm	10.93	10.91	10.91	10.98	10.96							
11	EPDM Thickness	2.40-3.00	mm	2.59	2.65	2.61	2.61	2.77							
12	Surface Hardness(HV)	min 560	HV	576.90	569.20	640.40	597.00	572.40							
13	Core Hardness(HV)	max 425	HV	400.30	412.40	390.70	386.60	399.70							
14	Torsional Strength(N.m)	min 10.9	N.m	15.75	15.75	15.52	16.19	15.77							
15	Drilling Test 1 (27kg 2500rpm 4.5mm)	max 5.0	Sec	2.70	3.20	3.12	2.76	2.77	3.14	3.11	2.89	2.89	3.10		

Inspection Results	<b>OK</b>
--------------------	-----------

Inspected	00075	Approved	
Date	2023/1/19	Date	

Phone: +886-7-6282702  
Fax: +886-7-6282602  
Email: info@broadenal.com.tw



Customer		Insp Cert No.	
P/O No.		Insp Cert Date	2023/3/24
Part No.	BN3-SDHC1225C3N	Batch No.	
Description	12-14 x 25mm, Hex Flange Head Self-drilling Screw, Dual-Edge Point, Silver Grey Ruspert 1000hrs, Green Line EPDM Washer, Head Mark: BN3, Drawing: BN3-SDHC1225C3		
Technical Diagram			

No	Inspect Item	Standard	Unit	Measured											
				1	2	3	4	5	6	7	8	9	10		
1	Across Corner	min 8.64	mm	8.99	8.97	8.98	8.99	8.99							
2	Across Flat	7.78-7.92	mm	7.83	7.84	7.84	7.86	7.87							
3	Washer Diameter	13.97-14.78	mm	14.38	14.35	14.37	14.24	14.26							
4	Total Head Height	5.08-5.92	mm	5.83	5.87	5.80	5.85	5.82							
5	Total Length	24.20-25.80	mm	25.06	25.15	25.05	25.07	25.04							
6	Pitch	1.81	mm	1.81	1.81	1.81	1.81	1.81							
7	Major Diameter	5.28-5.46	mm	5.43	5.42	5.44	5.42	5.42							
8	Drill Point Length	7.00-8.00	mm	7.35	7.45	7.56	7.49	7.25							
9	Drill Point Width	4.50-4.60	mm	4.59	4.58	4.59	4.58	4.57							
10	Outer Diameter(EPDM)	10.70-11.30	mm	10.96	10.97	10.93	10.93	10.94							
11	EPDM Thickness	2.40-3.00	mm	2.69	2.65	2.78	2.72	2.83							
12	Surface Hardness(HV)	min 560	HV	593.00	601.00	598.00	607.00	605.00							
13	Core Hardness(HV)	max 425	HV	416.00	419.00	412.00	413.00	418.00							
14	Torsional Strength(N.m)	min 10.9	N.m	14.40	15.47	14.66	14.82	15.01							
15	Drilling Test 1 (27kg 2500rpm 4.5mm)	max 5.0	Sec	2.80	2.50	2.80	2.95	2.85	2.92	3.20	2.71	3.51	2.66		

Inspection Results	<b>OK</b>
--------------------	-----------

Inspected	00075	Approved	
Date	2023/3/24	Date	



Phone: +886-7-6282702  
Fax: +886-7-6282602  
Email: info@broadenal.com.tw



Customer		Insp Cert No.	
P/O No.		Insp Cert Date	2023/3/16
Part No.	BN3-SDHC1230C3N	Batch No.	
Description	12-14 x 30mm, Hex Flange Head Self-drilling Screw, Dual-Edge Point, Silver Grey Ruspert 1000hrs, Green Line EPDM Washer, Head Mark: BN3, Drawing: BN3-SDHC1230C3		
Technical Diagram			

No	Inspect Item	Standard	Unit	Measured											
				1	2	3	4	5	6	7	8	9	10		
1	Across Corner	min 8.64	mm	8.82	8.83	8.86	8.81	8.86							
2	Across Flat	7.78-7.92	mm	7.85	7.84	7.82	7.86	7.85							
3	Washer Diameter	13.97-14.78	mm	14.30	14.16	14.38	14.24	14.39							
4	Total Head Height	5.08-5.92	mm	5.76	5.75	5.76	5.74	5.77							
5	Total Length	29.20-30.80	mm	30.16	30.15	30.05	30.13	30.01							
6	Pitch	1.81	mm	1.81	1.81	1.81	1.81	1.81							
7	Major Diameter	5.28-5.46	mm	5.39	5.39	5.39	5.40	5.41							
8	Drill Point Length	7.00-8.00	mm	7.55	7.58	7.47	7.62	7.53							
9	Drill Point Width	4.50-4.60	mm	4.57	4.59	4.55	4.59	4.59							
10	Outer Diameter(EPDM)	10.70-11.30	mm	10.93	10.92	10.90	10.98	10.93							
11	EPDM Thickness	2.40-3.30	mm	2.67	2.64	2.67	2.55	2.53							
12	Surface Hardness(HV)	min 560	HV	633.00	630.00	627.00	633.00	635.00							
13	Core Hardness(HV)	max 425	HV	416.00	412.00	417.00	412.00	416.00							
14	Torsional Strength(N.m)	min 10.9	N.m	14.19	14.66	14.60	14.58	14.18							
15	Drilling Test 1 (27kg 2500rpm 4.5mm)	max 5.0	Sec	2.67	3.38	3.12	3.49	2.75	2.71	2.93	3.20	2.79	2.89		

Inspection Results	<b>OK</b>
--------------------	-----------

Inspected	00067	Approved	
Date	2023/3/16	Date	

Phone: +886-7-6282702  
Fax: +886-7-6282602  
Email: info@broadenal.com.tw



Customer		Insp Cert No.	
P/O No.		Insp Cert Date	2023/2/13
Part No.	BN3-SDHC1235C3N	Batch No.	
Description	12-14 x 35mm, Hex Flange Head Self-drilling Screw, Dual-Edge Point, Silver Grey Ruspert 1000hrs, Green Line EPDM, Head Mark: BN3, Drawing: BN3-SDHC1235C3-DE		

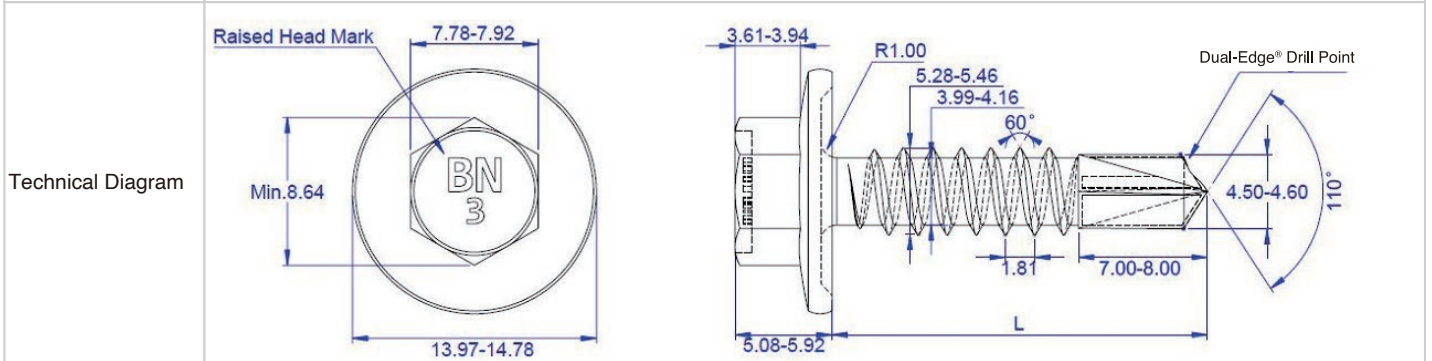

No	Inspect Item	Standard	Unit	Measured											
				1	2	3	4	5	6	7	8	9	10		
1	Across Corner	min 8.64	mm	8.98	8.97	8.93	8.99	8.98							
2	Across Flat	7.78-7.92	mm	7.90	7.85	7.86	7.89	7.87							
3	Washer Diameter	13.97-14.78	mm	14.14	14.19	14.14	14.12	14.32							
4	Total Head Height	5.08-5.92	mm	5.61	5.67	5.64	5.69	5.65							
5	Total Length	34.20-35.80	mm	34.61	34.81	34.76	34.68	34.92							
6	Pitch	1.81	mm	1.81	1.81	1.81	1.81	1.81							
7	Major Diameter	5.28-5.46	mm	5.39	5.39	5.40	5.39	5.39							
8	Drill Point Length	7.00-8.00	mm	7.59	7.69	7.67	7.53	7.61							
9	Drill Point Width	4.50-4.60	mm	4.59	4.56	4.57	4.58	4.57							
10	Outer Diameter(EPDM)	10.70-11.30	mm	11.06	11.08	11.07	10.96	10.98							
11	EPDM Thickness	2.40-3.00	mm	2.51	2.58	2.57	2.52	2.56							
12	Surface Hardness(HV)	min 560	HV	617.00	608.00	614.00	622.00	617.00							
13	Core Hardness(HV)	max 425	HV	414.00	413.00	409.00	412.00	415.00							
14	Torsional Strength(N.m)	min 10.9	N.m	14.09	14.35	14.67	14.60	14.53							
15	Drilling Test 1 (27kg 2500rpm 4.5mm)	max 5.0	Sec	2.72	2.73	2.78	2.85	2.51	2.71	2.73	2.65	2.83	2.76		

Inspection Results	<b>OK</b>
--------------------	-----------

Inspected	00045	Approved	
Date	2023/2/13	Date	

Phone: +886-7-6282702  
Fax: +886-7-6282602  
Email: info@broadenal.com.tw



Customer		Insp Cert No.	
P/O No.		Insp Cert Date	2023/4/6
Part No.	BN3-SDHC1245C3N	Batch No.	
Description	12-14 x 45mm, Hex Flange Head Self-drilling Screw, Dual-Edge Point, Silver Grey Ruspert 1000hrs, Green Line EPDM Washer, Head Mark: BN3, Drawing: BN3-SDHC1245C3		
Technical Diagram			

No	Inspect Item	Standard	Unit	Measured											
				1	2	3	4	5	6	7	8	9	10		
1	Across Corner	min8.64	mm	8.97	8.94	8.95	8.93	8.98							
2	Across Flat	7.78-7.92	mm	7.85	7.87	7.88	7.86	7.87							
3	Washer Diameter	13.97-14.78	mm	14.34	14.24	14.23	14.22	14.18							
4	Total Head Height	5.08-5.92	mm	5.85	5.73	5.89	5.88	5.92							
5	Total Length	44.20-45.80	mm	44.54	44.63	44.54	44.87	44.46							
6	Major Diameter	5.28-5.46	mm	5.43	5.43	5.44	5.42	5.43							
7	Pitch	1.81	mm	1.81	1.81	1.81	1.81	1.81							
8	Drill Point Length	7.00-8.00	mm	7.72	7.69	7.86	7.73	7.81							
9	Drill Point Width	4.50-4.60	mm	4.55	4.53	4.56	4.53	4.52							
10	Outer Diameter(EPDM)	10.70-11.30	mm	10.94	10.90	10.95	10.94	10.95							
11	EPDM Thickness	2.40-3.00	mm	2.73	2.60	2.72	2.75	2.70							
12	Surface Hardness(HV)	min560	HV	603.00	617.00	609.00	611.00	615.00							
13	Core Hardness(HV)	max425	HV	411.00	419.00	413.00	418.00	415.00							
14	Torsional Strength(N.m)	min10.9	N.m	15.14	15.63	15.16	15.75	15.52							
15	Drilling Test 1 (27kg2500rpm4.5mm)	max5.0	Sec	2.33	2.52	2.25	2.32	2.14	2.25	2.21	2.64	2.43	2.23		

Inspection Results	<b>OK</b>
--------------------	-----------

Inspected	00075	Approved	
Date	2023/4/6	Date	

Phone: +886-7-6282702  
Fax: +886-7-6282602  
Email: info@broadenal.com.tw



Customer		Insp Cert No.	
P/O No.		Insp Cert Date	2023/3/14
Part No.	BN3-SDHC1255C3N	Batch No.	
Description	12-14 x 55mm, Hex Flange Head Self-drilling Screw, Dual-Edge Point, Silver Grey Ruspert 1000hrs, Green Line EPDM, Head Mark: BN3, Drawing: BN3-SDHC1255C3-DE		

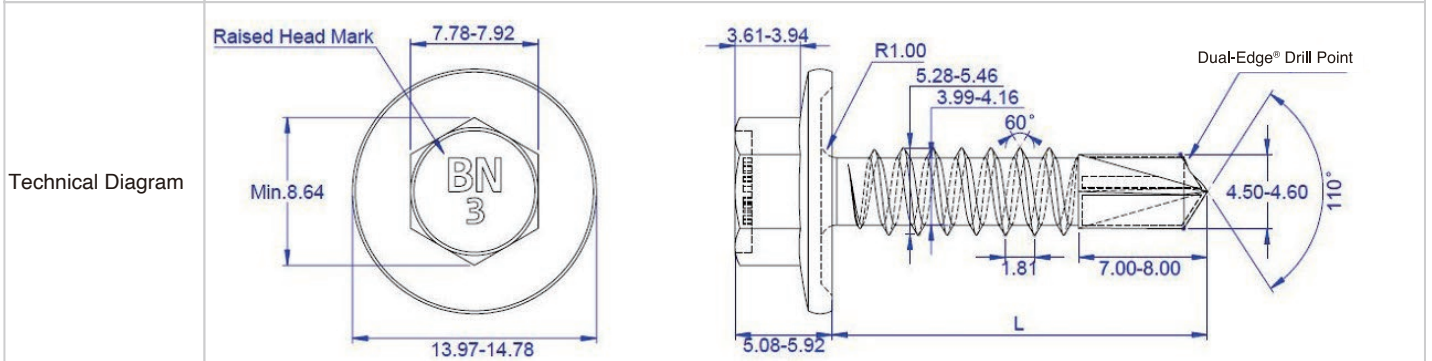

No	Inspect Item	Standard	Unit	Measured											
				1	2	3	4	5	6	7	8	9	10		
1	Across Corner	min 8.64	mm	9.00	8.97	8.97	8.80	8.99							
2	Across Flat	7.78-7.92	mm	7.88	7.88	7.85	7.85	7.85							
3	Washer Diameter	13.97-14.78	mm	14.40	14.33	14.35	14.33	14.23							
4	Total Head Height	5.08-5.92	mm	5.69	5.57	5.64	5.60	5.61							
5	Total Length	54.20-55.80	mm	54.84	54.97	54.97	54.92	54.78							
6	Pitch	1.81	mm	1.81	1.81	1.81	1.81	1.81							
7	Major Diameter	5.28-5.46	mm	5.42	5.43	5.43	5.42	5.42							
8	Drill Point Length	7.00-8.00	mm	7.59	7.38	7.62	7.41	7.47							
9	Drill Point Width	4.50-4.60	mm	4.58	4.60	4.59	4.58	4.59							
10	Outer Diameter(EPDM)	10.70-11.30	mm	11.05	11.09	11.10	11.07	10.99							
11	EPDM Thickness	2.40-3.00	mm	2.50	2.55	2.51	2.63	2.56							
12	Surface Hardness(HV)	min 560	HV	621.00	613.00	620.00	611.00	618.00							
13	Core Hardness(HV)	max 425	HV	416.00	410.00	415.00	412.00	415.00							
14	Torsional Strength(N.m)	min 10.9	N.m	13.99	13.93	14.71	14.81	14.40							
15	Drilling Test 1 (27kg 2500rpm 4.5mm)	max 5.0	Sec	2.71	3.30	2.74	2.47	2.79	2.75	2.48	2.34	2.44	2.41		

Inspection Results	<b>OK</b>
--------------------	-----------

Inspected	00045	Approved	
Date	2023/3/14	Date	

Phone: +886-7-6282702  
Fax: +886-7-6282602  
Email: info@broadenal.com.tw



Customer		Insp Cert No.	
P/O No.		Insp Cert Date	2023/3/15
Part No.	BN3-SDHC1265C3N	Batch No.	
Description	12-14 x 65mm, Hex Flange Head Self-drilling Screw, Dual-Edge Point, Silver Grey Ruspert 1000hrs, Green Line EPDM Washer, Head Mark: BN3, Drawing: BN3-SDHC1265C3		
Technical Diagram			

No	Inspect Item	Standard	Unit	Measured											
				1	2	3	4	5	6	7	8	9	10		
1	Across Corner	min8.64	mm	8.72	8.78	8.73	8.73	8.75							
2	Across Flat	7.78-7.92	mm	7.83	7.83	7.85	7.84	7.86							
3	Washer Diameter	13.97-14.78	mm	14.14	14.40	14.34	14.29	14.35							
4	Total Head Height	5.08-5.92	mm	5.23	5.20	5.25	5.19	5.19							
5	Total Length	64.00-66.00	mm	64.55	64.49	64.65	64.68	64.62							
6	Major Diameter	5.28-5.46	mm	5.42	5.37	5.40	5.40	5.41							
7	Pitch	1.81	mm	1.81	1.81	1.81	1.81	1.81							
8	Drill Point Length	7.00-8.00	mm	7.37	7.13	7.09	7.50	7.25							
9	Drill Point Width	4.50-4.60	mm	4.57	4.59	4.58	4.55	4.56							
10	Outer Diameter(EPDM)	10.70-11.30	mm	10.94	10.99	10.95	10.93	10.91							
11	EPDM Thickness	2.40-3.00	mm	2.76	2.81	2.76	2.81	2.77							
12	Surface Hardness(HV)	min560	HV	633.00	630.00	628.00	631.00	629.00							
13	Core Hardness(HV)	max425	HV	415.00	412.00	417.00	411.00	416.00							
14	Torsional Strength(N.m)	min10.9	N.m	14.16	13.93	13.88	14.00	14.09							
15	Drilling Test 1 (27kg 2500rpm 4.5mm)	max5.0	Sec	2.62	2.54	2.79	2.52	2.85	2.76	2.75	2.67	2.59	2.47		

Inspection Results	<b>OK</b>
--------------------	-----------

Inspected	00120	Approved	
Date	2023/3/15	Date	

Phone: +886-7-6282702  
Fax: +886-7-6282602  
Email: info@broadenal.com.tw



Customer		Insp Cert No.	
P/O No.		Insp Cert Date	2023/3/25
Part No.	BN3-SDHC1275C3N	Batch No.	
Description	12-14 x 75mm, Hex Flange Head Self-drilling Screw, Dual-Edge Point, Silver Grey Ruspert 1000hrs, Green Line EPDM, Head Mark: BN3, Drawing: BN3-SDHC1275C3-DE		

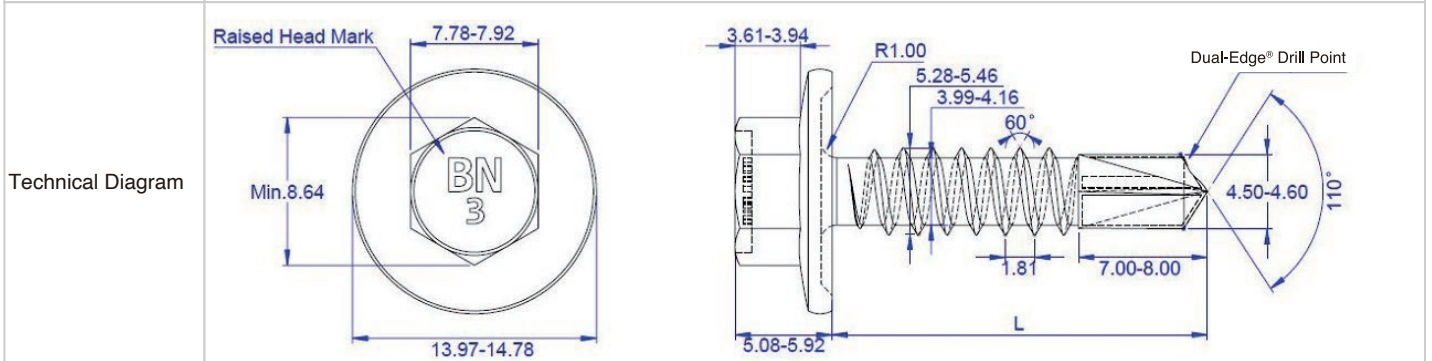

No	Inspect Item	Standard	Unit	Measured											
				1	2	3	4	5	6	7	8	9	10		
1	Across Corner	min 8.64	mm	8.99	9.00	8.99	8.99	9.00							
2	Across Flat	7.78-7.92	mm	7.88	7.87	7.89	7.85	7.85							
3	Washer Diameter	13.97-14.78	mm	14.25	14.20	14.35	14.31	14.32							
4	Total Head Height	5.08-5.92	mm	5.67	5.67	5.68	5.71	5.67							
5	Total Length	74.00-76.00	mm	74.69	74.86	74.77	74.93	74.83							
6	Pitch	1.81	mm	1.81	1.81	1.81	1.81	1.81							
7	Major Diameter	5.28-5.46	mm	5.44	5.44	5.44	5.44	5.44							
8	Drill Point Length	7.00-8.00	mm	7.73	7.90	7.72	7.84	7.61							
9	Drill Point Width	4.50-4.60	mm	4.54	4.57	4.60	4.59	4.56							
10	Outer Diameter(EPDM)	10.70-11.30	mm	10.98	10.96	11.01	11.04	10.93							
11	EPDM Thickness	2.40-3.00	mm	2.58	2.60	2.56	2.53	2.61							
12	Surface Hardness(HV)	min 560	HV	591.50	625.20	599.70	591.40	595.50							
13	Core Hardness(HV)	max 425	HV	406.90	404.70	398.10	417.00	391.80							
14	Torsional Strength(N.m)	min 10.9	N.m	13.80	13.36	13.80	14.39	14.24							
15	Drilling Test 1 (27kg 2500rpm 4.5mm)	max 5.0	Sec	2.16	2.52	2.20	2.34	2.21	2.43	2.58	2.95	2.81	4.97		

Inspection Results	<b>OK</b>
--------------------	-----------

Inspected	00045	Approved	
Date	2023/3/25	Date	

Phone: +886-7-6282702  
Fax: +886-7-6282602  
Email: info@broadenal.com.tw



Customer		Insp Cert No.	
P/O No.		Insp Cert Date	2023/3/14
Part No.	BN3-SDHC1290C3N	Batch No.	
Description	12-14 x 90mm, Hex Flange Head Self-drilling Screw, Dual-Edge Point, Silver Grey Ruspert 1000hrs, Green Line EPDM, Head Mark: BN3, Drawing: BN3-SDHC1290C3-DE		

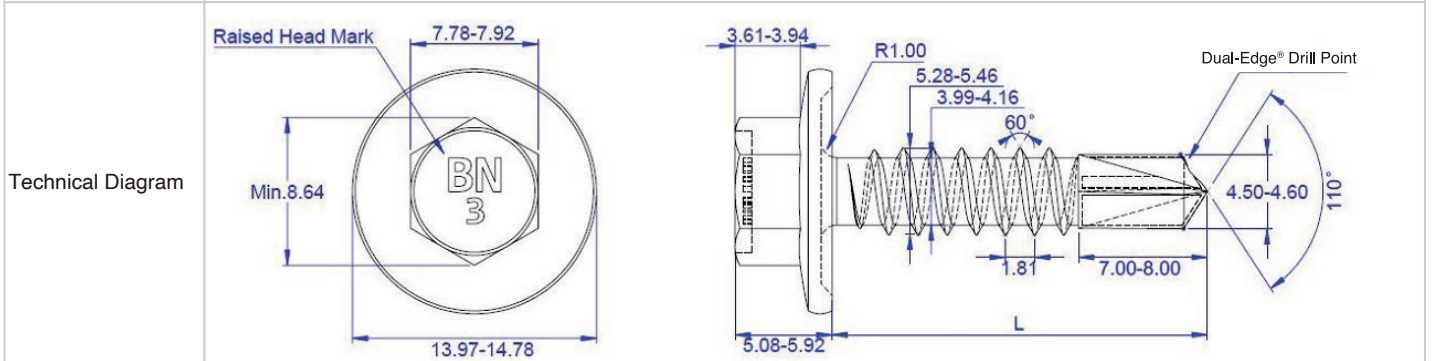

No	Inspect Item	Standard	Unit	Measured											
				1	2	3	4	5	6	7	8	9	10		
1	Across Corner	min 8.64	mm	8.88	8.91	8.94	8.86	8.94							
2	Across Flat	7.78-7.92	mm	7.82	7.82	7.83	7.83	7.84							
3	Washer Diameter	13.97-14.78	mm	14.45	14.38	14.38	14.46	14.38							
4	Total Head Height	5.08-5.92	mm	5.58	5.62	5.66	5.62	5.65							
5	Total Length	89.00-91.00	mm	89.72	89.79	89.71	89.73	89.61							
6	Pitch	1.81	mm	1.81	1.81	1.81	1.81	1.81							
7	Major Diameter	5.28-5.46	mm	5.38	5.38	5.38	5.39	5.39							
8	Drill Point Length	7.00-8.00	mm	7.63	7.61	7.73	7.73	7.71							
9	Drill Point Width	4.50-4.60	mm	4.57	4.58	4.56	4.59	4.56							
10	Outer Diameter(EPDM)	10.70-11.30	mm	11.01	10.97	11.03	11.05	11.08							
11	EPDM Thickness	2.40-3.00	mm	2.67	2.52	2.64	2.53	2.52							
12	Surface Hardness(HV)	min 560	HV	575.60	595.50	591.40	583.50	608.00							
13	Core Hardness(HV)	max 425	HV	395.00	396.00	389.70	397.10	403.60							
14	Torsional Strength(N.m)	min 10.9	N.m	13.61	14.18	14.59	14.09	14.33							
15	Drilling Test 1 (27kg 2500rpm 4.5mm)	max 5.0	Sec	2.33	2.92	2.14	2.66	2.40	2.56	2.39	2.54	2.51	2.51		

Inspection Results	<b>OK</b>
--------------------	-----------

Inspected	00067	Approved	
Date	2023/3/14	Date	

Phone: +886-7-6282702  
Fax: +886-7-6282602  
Email: info@broadenal.com.tw



Customer		Insp Cert No.	
P/O No.		Insp Cert Date	2023/3/17
Part No.	BN3-SDHCG1250C3N	Batch No.	
Description	12-14 x 50mm, Hex Flange Head Self-drilling Screw, Double Thread, Dual-Edge Point, Silver Grey Ruspert 1000hrs, Green Line EPDM Washer, Head Mark: BN3, Drawing: BN3-SDHCG1250C3		
Technical Diagram			

No	Inspect Item	Standard	Unit	Measured										
				1	2	3	4	5	6	7	8	9	10	
1	Across Corner	min 8.64	mm	8.83	8.85	8.83	8.82	8.80						
2	Across Flat	7.78-7.92	mm	7.83	7.88	7.84	7.80	7.85						
3	Washer Diameter	13.97-14.78	mm	14.16	14.27	14.25	14.37	14.40						
4	Total Head Height	5.08-5.92	mm	5.72	5.78	5.76	5.75	5.74						
5	Total Length	47.50-49.00	mm	48.41	48.54	48.55	48.23	48.52						
6	Shankguard Diameter	4.60-5.10	mm	4.82	4.86	4.82	4.88	4.85						
7	Upper Thread Major Diameter	6.10-6.25	mm	6.17	6.16	6.10	6.14	6.19						
8	Lower Thread Major Diameter	5.31-5.46	mm	5.41	5.41	5.43	5.38	5.43						
9	Upper Thread Length	8.50-9.50	mm	9.09	9.21	9.39	9.12	9.31						
10	Lower Thread Length	REF 30.00	mm	30.65	30.67	30.90	30.81	30.88						
11	Lower Thread Pitch	1.81	mm	1.81	1.81	1.81	1.81	1.81						
12	Drill Point Length	8.00-9.00	mm	8.28	8.27	8.30	8.48	8.19						
13	Drill Point Width	4.55-4.70	mm	4.61	4.61	4.60	4.62	4.60						
14	Outer Diameter(EPDM)	10.70-11.30	mm	11.16	11.14	11.07	11.14	11.06						
15	EPDM Thickness	2.40-3.00	mm	2.71	2.66	2.72	2.67	2.64						
16	Surface Hardness(HV)	min 560	HV	616.00	600.00	623.00	608.00	627.00						
17	Core Hardness(HV)	max 425	HV	410.00	405.00	412.00	408.00	413.00						
18	Torsional Strength(N.m)	min 10.9	N.m	14.57	14.78	14.58	14.38	14.76						
19	Drilling Test 1 (27kg 2500rpm 4.5mm)	max 5.0	Sec	3.49	3.06	2.53	2.95	3.61	2.58	3.23	2.91	3.36	3.20	

Inspection Results	<b>OK</b>	Inspected	00120	Approved	
		Date	2023/3/17	Date	





Fax: +886-7-6282602  
Email: info@broadenal.com.tw

Customer		Insp Cert No.	
P/O No.		Insp Cert Date	2023/4/6
Part No.	BN3-SDHCG1255C3N	Batch No.	
Description	12-14 x 55mm, Hex Flange Head Self-drilling Screw, Dual-Edge Point, Double Thread, Silver Grey Ruspert 1000hrs, Green Line EPDM Washer, Head Mark: BN3, Drawing: BN3-SDHCG1255C3		
Technical Diagram			

No	Inspect Item	Standard	Unit	Measured										
				1	2	3	4	5	6	7	8	9	10	
1	Across Corner	min 8.64	mm	8.88	8.88	8.89	8.89	8.89						
2	Across Flat	7.78-7.92	mm	7.85	7.83	7.89	7.83	7.82						
3	Washer Diameter	13.97-14.78	mm	14.28	14.18	14.13	14.23	14.39						
4	Total Head Height	5.08-5.92	mm	5.79	5.81	5.82	5.83	5.77						
5	Total Length	53.50-55.00	mm	54.20	54.16	54.23	54.28	54.07						
6	Shankguard Diameter	4.60-5.10	mm	4.75	4.83	4.78	4.81	4.79						
7	Upper Thread Major Diameter	6.10-6.25	mm	6.22	6.20	6.19	6.21	6.21						
8	Lower Thread Major Diameter	5.31-5.46	mm	5.40	5.40	5.40	5.40	5.40						
9	Upper Thread Length	8.50-9.50	mm	9.21	9.40	9.30	9.36	9.22						
10	Lower Thread Length	REF 34.00	mm	34.66	34.86	34.81	34.89	34.66						
11	Lower Thread Pitch	1.81	mm	1.81	1.81	1.81	1.81	1.81						
12	Drill Point Length	8.00-9.00	mm	8.72	8.90	8.71	8.73	8.98						
13	Drill Point Width	4.55-4.70	mm	4.57	4.57	4.58	4.59	4.62						
14	Outer Diameter(EPDM)	10.70-11.30	mm	11.18	11.20	11.11	11.08	11.06						
15	EPDM Thickness	2.40-3.00	mm	2.70	2.65	2.62	2.66	2.72						
16	Surface Hardness(HV)	min 560	HV	636.00	639.00	630.00	638.00	635.00						
17	Core Hardness(HV)	max 425	HV	415.00	411.00	415.00	413.00	414.00						
18	Torsional Strength(N.m)	min 10.9	N.m	15.80	15.88	15.62	15.79	15.37						
19	Drilling Test 1 (27kg 2500rpm 4.5mm)	max 5.0	Sec	2.44	2.52	2.74	2.76	3.27	2.42	2.99	2.44	2.80	3.09	

Inspection Results	<b>OK</b>	Inspected	00045	Approved	
		Date	2023/4/6	Date	

Phone: +886-7-6282702  
Fax: +886-7-6282602  
Email: info@broadenal.com.tw



Customer		Insp Cert No.	
P/O No.		Insp Cert Date	2023/3/14
Part No.	BN3-SDHCG1265C3N	Batch No.	
Description	12-14 x 65mm, Hex Flange Head Self-drilling Screw, Dual-Edge Point, Double Thread, Silver Grey Ruspert 1000hrs, Green Line EPDM Washer, Head Mark: BN3, Drawing: BN3-SDHCG1265C3		

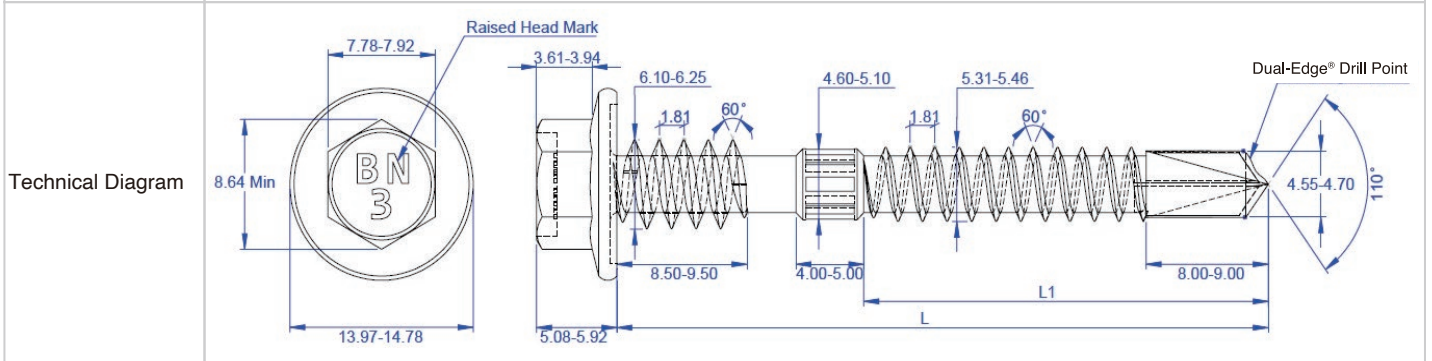

No	Inspect Item	Standard	Unit	Measured										
				1	2	3	4	5	6	7	8	9	10	
1	Across Corner	min 8.64	mm	8.98	9.00	8.93	8.94	8.97						
2	Across Flat	7.78-7.92	mm	7.85	7.83	7.85	7.88	7.87						
3	Washer Diameter	13.97-14.78	mm	14.24	14.23	14.21	14.34	14.26						
4	Total Head Height	5.08-5.92	mm	5.80	5.87	5.62	5.85	5.85						
5	Upper Thread Major Diameter	6.10-6.25	mm	6.21	6.23	6.23	6.22	6.21						
6	Lower Thread Major Diameter	5.31-5.46	mm	5.45	5.44	5.45	5.44	5.46						
7	Total Length	65.50-67.00	mm	66.42	66.37	66.28	66.28	66.34						
8	Shankguard Diameter	4.60-5.10	mm	4.86	4.87	4.97	4.93	4.91						
9	Upper Thread Length	8.50-9.50	mm	8.85	9.08	9.17	8.95	9.18						
10	Lower Thread Length	REF 37.00	mm	37.33	37.56	37.22	37.31	37.18						
11	Pitch	1.81	mm	1.81	1.81	1.81	1.81	1.81						
12	Drill Point Length	8.00-9.00	mm	8.54	8.39	8.39	8.58	8.46						
13	Drill Point Width	4.55-4.70	mm	4.63	4.64	4.65	4.63	4.62						
14	Outer Diameter(EPDM)	10.70-11.30	mm	10.86	10.98	10.97	10.89	10.97						
15	EPDM Thickness	2.40-3.00	mm	2.67	2.70	2.68	2.69	2.72						
16	Surface Hardness(HV)	min 560	HV	611.00	628.00	617.00	625.00	619.00						
17	Core Hardness(HV)	max 425	HV	411.00	413.00	419.00	412.00	418.00						
18	Torsional Strength(N.m)	min 10.9	N.m	15.01	14.97	14.83	15.03	14.92						
19	Drilling Test 1 (27kg 2500rpm 4.5mm)	max 5.0	Sec	3.06	2.50	2.29	2.34	2.66	2.53	2.47	2.32	2.91	2.88	

Inspection Results	<b>OK</b>	Inspected	00096	Approved	
		Date	2023/3/14	Date	

Phone: +886-7-6282702  
Fax: +886-7-6282602  
Email: info@broadenal.com.tw



Customer		Insp Cert No.	
P/O No.		Insp Cert Date	2023/4/14
Part No.	BN3-SDHCG1275C3N	Batch No.	
Description	12-14 x 75mm, Hex Flange Head Self-drilling Screw, Dual-Edge Point, Double Thread, Silver Grey Ruspert 1000hrs, Green Line EPDM Washer, Head Mark: BN3, Drawing: BN3-SDHCG1275C3		

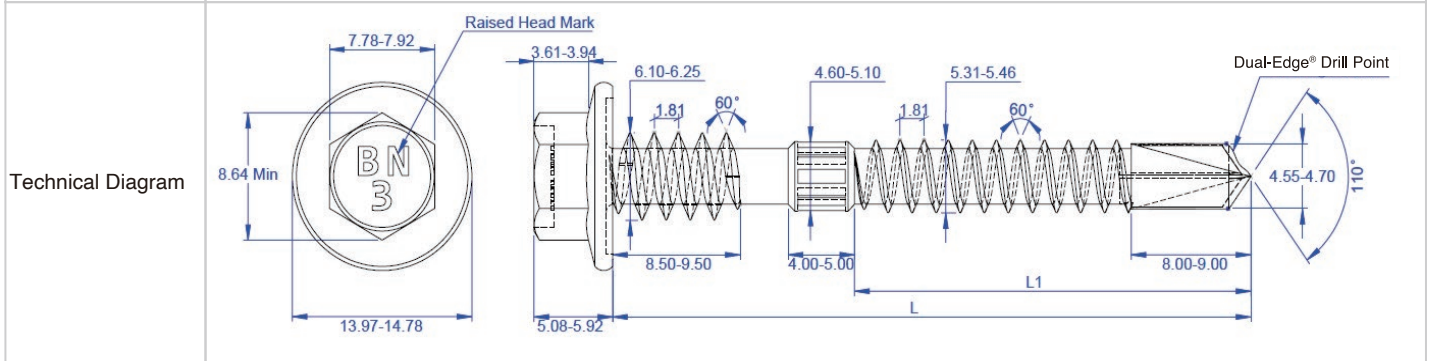

No	Inspect Item	Standard	Unit	Measured											
				1	2	3	4	5	6	7	8	9	10		
1	Across Corner	min 8.64	mm	8.99	8.98	8.99	8.98	8.99							
2	Across Flat	7.78-7.92	mm	7.84	7.85	7.85	7.83	7.82							
3	Washer Diameter	13.97-14.78	mm	14.30	14.16	14.42	14.23	14.33							
4	Total Head Height	5.08-5.92	mm	5.72	5.77	5.77	5.72	5.79							
5	Upper Thread Major Diameter	6.10-6.25	mm	6.17	6.20	6.18	6.20	6.19							
6	Lower Thread Major Diameter	5.31-5.46	mm	5.42	5.43	5.43	5.42	5.42							
7	Total Length	73.50-75.00	mm	74.42	74.80	74.42	74.39	74.43							
8	Shankguard Diameter	4.60-5.10	mm	4.76	4.86	4.85	4.83	4.83							
9	Upper Thread Length	8.50-9.50	mm	9.21	9.05	9.39	8.91	9.00							
10	Lower Thread Length	REF 43.00	mm	43.04	43.06	43.15	43.17	43.05							
11	Pitch	1.81	mm	1.81	1.81	1.81	1.81	1.81							
12	Drill Point Length	8.00-9.00	mm	8.50	8.51	8.60	8.56	8.87							
13	Drill Point Width	4.55-4.70	mm	4.63	4.65	4.65	4.65	4.66							
14	Outer Diameter(EPDM)	10.70-11.30	mm	11.08	10.86	10.77	10.89	10.94							
15	EPDM Thickness	2.40-3.00	mm	2.66	2.69	2.68	2.66	2.76							
16	Surface Hardness(HV)	min 560	HV	628.00	613.00	635.00	622.00	639.00							
17	Core Hardness(HV)	max 425	HV	411.00	406.00	413.00	409.00	414.00							
18	Torsional Strength(N.m)	min 10.9	N.m	14.23	14.10	14.29	14.39	14.21							
19	Drilling Test 1 (27kg 2500rpm 4.5mm)	max 5.0	Sec	2.69	4.32	2.82	2.83	2.51	2.72	3.11	2.60	2.29	2.89		

Inspection Results	<b>OK</b>	Inspected	00096	Approved	
		Date	2023/4/14	Date	



Fax: +886-7-6282602  
Email: info@broadenal.com.tw

Customer		Insp Cert No.	
P/O No.		Insp Cert Date	2023/4/17
Part No.	BN3-SDHCG1285C3N	Batch No.	
Description	12-14 x 85mm, Hex Flange Head Self-drilling Screw, Double Thread, Dual-Edge Point, Silver Grey Ruspert 1000hrs, Green Line EPDM Washer, Head Mark: BN3, Drawing: BN3-SDHCG1285C3		
Technical Diagram			

No	Inspect Item	Standard	Unit	Measured											
				1	2	3	4	5	6	7	8	9	10		
1	Across Corner	min 8.64	mm	8.97	8.95	8.95	8.99	8.98							
2	Across Flat	7.78-7.92	mm	7.88	7.87	7.84	7.88	7.89							
3	Washer Diameter	13.97-14.78	mm	14.33	14.36	14.29	14.36	14.32							
4	Total Head Height	5.08-5.92	mm	5.75	5.76	5.72	5.68	5.77							
5	Upper Thread Major Diameter	6.10-6.25	mm	6.25	6.24	6.24	6.25	6.25							
6	Lower Thread Major Diameter	5.31-5.46	mm	5.40	5.40	5.39	5.38	5.40							
7	Total Length	83.50-85.00	mm	84.38	84.41	84.46	84.00	84.52							
8	Shankguard Diameter	4.60-5.10	mm	4.86	4.85	4.85	4.83	4.83							
9	Upper Thread Length	8.50-9.50	mm	8.57	8.78	8.62	8.54	8.76							
10	Lower Thread Length	REF 43.00	mm	43.96	43.78	43.39	43.68	43.25							
11	Pitch	1.81	mm	1.81	1.81	1.81	1.81	1.81							
12	Drill Point Length	8.00-9.00	mm	8.88	8.68	8.63	8.91	8.40							
13	Drill Point Width	4.55-4.70	mm	4.61	4.61	4.61	4.57	4.60							
14	Outer Diameter(EPDM)	10.70-11.30	mm	11.24	11.10	10.95	11.16	11.06							
15	EPDM Thickness	2.60-3.00	mm	2.80	2.86	2.83	2.72	2.76							
16	Surface Hardness(HV)	min 560	HV	611.00	606.00	605.00	607.00	599.00							
17	Core Hardness(HV)	max 425	HV	411.00	413.00	417.00	411.00	409.00							
18	Torsional Strength(N.m)	min 10.9	N.m	15.31	14.87	15.42	14.93	15.13							
19	Drilling Test 1 (27kg 2500rpm 4.5mm)	max 5.0	Sec	2.87	2.25	2.51	3.32	2.16	2.47	2.36	2.92	2.45	2.98		

Inspection Results	<b>OK</b>	Inspected	00075	Approved	
		Date	2023/4/17	Date	

Phone: +886-7-6282702  
Fax: +886-7-6282602  
Email: info@broadenal.com.tw



Customer		Insp Cert No.	
P/O No.		Insp Cert Date	2023/2/20
Part No.	BN3-SDHCG12110C3N	Batch No.	
Description	12-14 x 110mm, Hex Flange Head Self-drilling Screw, Double Thread, Dual-Edge Point, Silver Grey Ruspert 1000hrs, Green Line EPDM, Head Mark: BN3, Drawing: BN3-SDHCG12110C3		
Technical Diagram			

No	Inspect Item	Standard	Unit	Measured										
				1	2	3	4	5	6	7	8	9	10	
1	Across Corner	min 8.64	mm	8.94	8.95	8.91	8.96	8.91						
2	Across Flat	7.78-7.98	mm	7.83	7.87	7.87	7.86	7.87						
3	Washer Diameter	13.97-14.78	mm	14.12	14.21	14.25	14.37	14.31						
4	Total Head Height	5.92-6.30	mm	6.18	6.03	6.18	6.27	6.06						
5	Washer Thickness	1.98-2.10	mm	2.06	2.07	2.09	2.07	2.07						
6	Upper Thread Major Diameter	6.10-6.25	mm	6.20	6.20	6.21	6.20	6.22						
7	Lower Thread Major Diameter	5.31-5.46	mm	5.40	5.40	5.41	5.42	5.39						
8	Total Length	109.00-111.00	mm	110.25	110.36	110.48	110.67	110.30						
9	Shankguard Diameter	4.60-5.10	mm	4.77	4.76	4.79	4.76	4.78						
10	Upper Thread Length	8.50-9.50	mm	8.61	8.74	8.57	8.62	8.59						
11	Lower Thread Length	REF 75.00	mm	74.98	75.07	75.09	75.12	74.97						
12	Lower Thread Pitch	1.81	mm	1.81	1.81	1.81	1.81	1.81						
13	Drill Point Length	8.00-9.00	mm	8.61	8.67	8.69	8.69	8.74						
14	Drill Point Width	4.55-4.70	mm	4.58	4.59	4.62	4.59	4.58						
15	EPDM Thickness	2.40-3.00	mm	2.65	2.63	2.60	2.64	2.61						
16	Outer Diameter(EPDM)	10.70-11.30	mm	11.02	11.10	11.01	11.04	11.04						
17	Surface Hardness(HV)	min 560	HV	637.00	630.00	641.00	633.00	641.00						
18	Core Hardness(HV)	max 425	HV	415.00	413.00	415.00	416.00	411.00						
19	Torsional Strength(N.m)	min 10.9	N.m	14.45	14.76	14.56	14.86	14.62						
20	Drilling Test 1 (27kg 2500rpm 4.5mm)	max 5.0	Sec	3.05	3.35	4.20	3.31	2.52	2.94	2.64	2.66	3.63	3.46	

Inspection Results	<b>OK</b>
--------------------	-----------

Inspected	00067	Approved	
Date	2023/2/20	Date	



Fax: +886-7-6282602  
Email: info@broadenal.com.tw

Customer		Insp Cert No.	
P/O No.		Insp Cert Date	2023/1/17
Part No.	BN3-SDHCG12130C3N	Batch No.	
Description	12-14 x 130mm, Hex Flange Head Self-drilling Screw, Double Thread, Dual-Edge Point, Silver Grey Ruspert 1000hrs, Green Line EPDM Washer, Head Mark: BN3, Drawing: BN3-SDHCG12130C3		
Technical Diagram			

No	Inspect Item	Standard	Unit	Measured											
				1	2	3	4	5	6	7	8	9	10		
1	Across Corner	min 8.64	mm	8.95	8.97	8.96	8.98	8.96							
2	Across Flat	7.78-7.98	mm	7.82	7.84	7.83	7.81	7.81							
3	Washer Diameter	13.97-14.78	mm	14.28	14.33	14.18	14.28	14.28							
4	Total Head Height	5.92-6.30	mm	6.08	6.05	6.08	6.13	6.04							
5	Washer Thickness	1.98-2.10	mm	2.10	2.09	2.10	2.09	2.10							
6	Upper Thread Major Diameter	6.10-6.25	mm	6.15	6.12	6.12	6.12	6.12							
7	Lower Thread Major Diameter	5.31-5.46	mm	5.41	5.42	5.41	5.40	5.41							
8	Total Length	129.00-131.00	mm	130.07	130.21	130.27	130.30	130.38							
9	Shankguard Diameter	4.60-5.10	mm	4.79	4.85	4.83	4.87	4.79							
10	Upper Thread Length	8.50-9.50	mm	9.38	9.22	9.23	9.38	9.37							
11	Lower Thread Length	REF 75.00	mm	74.57	74.90	75.09	74.93	74.84							
12	Lower Thread Pitch	1.81	mm	1.81	1.81	1.81	1.81	1.81							
13	Drill Point Length	8.00-9.00	mm	8.41	8.15	8.56	8.55	8.63							
14	Drill Point Width	4.55-4.70	mm	4.61	4.61	4.60	4.60	4.64							
15	Outer Diameter(EPDM)	10.70-11.30	mm	11.17	10.95	11.21	11.05	11.14							
16	EPDM Thickness	2.40-3.00	mm	2.62	2.79	2.75	2.69	2.71							
17	Surface Hardness(HV)	min 560	HV	610.00	614.00	649.00	642.00	630.00							
18	Core Hardness(HV)	max 425	HV	418.00	421.00	400.00	412.00	412.00							
19	Torsional Strength(N.m)	min 10.9	N.m	12.96	12.68	12.44	12.96	12.58							
20	Drilling Test 1 (27kg 2500rpm 4.5mm)	max 5.0	Sec	3.55	3.07	3.70	3.26	2.60	3.23	2.94	2.74	2.70	2.58		

Inspection Results	OK
--------------------	----

Inspected	00045	Approved	
Date	2023/1/17	Date	

Phone: +886-7-6282702  
Fax: +886-7-6282602  
Email: info@broadenal.com.tw



Customer		Insp Cert No.	QC23030029
P/O No.		Insp Cert Date	2023/3/3
Part No.	BN3-SDH5F1232C3N	Batch No.	

Description: 12-24 x 32mm, Hex Flange Head Self-drilling Screw, No.5 Point, Silver Grey Ruspert 1000hrs, Green Line EPDM Washer, Head Mark: BN3, Drawing: BDN-SDH5F1232C3

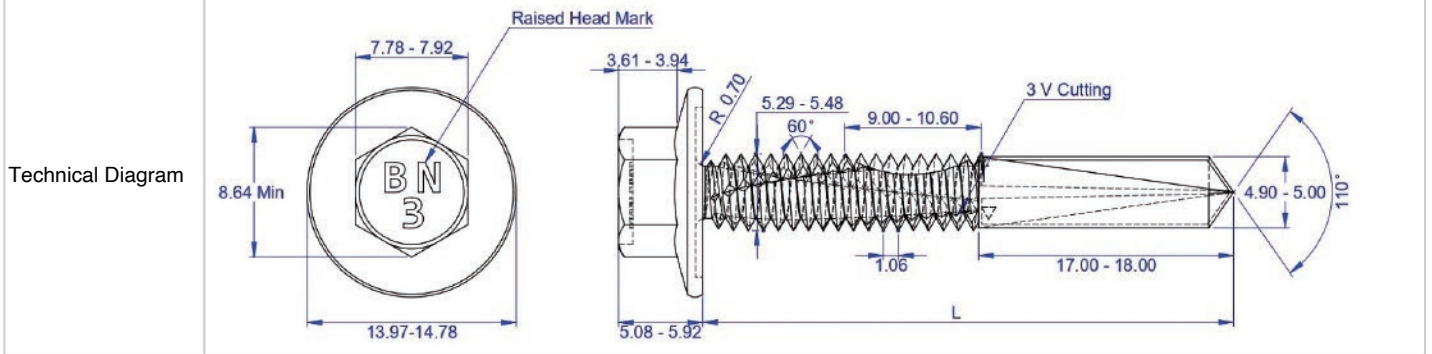

No	Inspect Item	Standard	Unit	Measured											
				1	2	3	4	5	6	7	8	9	10		
1	Across Corner	min 8.64	mm	8.99	8.99	9.00	9.00	8.99							
2	Across Flat	7.78-7.92	mm	7.86	7.86	7.87	7.87	7.88							
3	Washer Diameter	13.97-14.78	mm	14.33	14.31	14.30	14.21	14.29							
4	Total Head Height	5.08-5.92	mm	5.70	5.73	5.71	5.78	5.71							
5	Total Length	31.20-32.80	mm	32.08	31.94	31.95	31.74	31.99							
6	Pitch	1.06	mm	1.06	1.06	1.06	1.06	1.06							
7	Major Diameter	5.29-5.48	mm	5.38	5.40	5.40	5.44	5.38							
8	Drill Point Length	17.00-18.00	mm	17.47	17.49	17.87	17.43	17.66							
9	Drill Point Width	4.90-5.00	mm	4.96	5.00	4.98	4.92	4.97							
10	Outer Diameter(EPDM)	10.70-11.30	mm	10.96	10.98	11.06	11.02	11.04							
11	EPDM Thickness	2.40-3.00	mm	2.50	2.50	2.59	2.60	2.54							
12	Surface Hardness(HV)	min 560	HV	655.00	644.00	653.00	647.00	648.00							
13	Core Hardness(HV)	max 425	HV	390.00	392.00	392.00	387.00	382.00							
14	Torsional Strength(N.m)	min 10.9	N.m	15.75	15.13	16.06	16.12	16.31							
15	Drilling Test 1 (25kg 1800rpm 12mm)	max 25.0	Sec	9.93	10.62	12.47	8.83	10.98	10.26	9.60	10.13	11.70	10.45		

Inspection Results	<b>OK</b>	Inspected	00045	Approved	
		Date	2023/3/3	Date	

Phone: +886-7-6282702  
Fax: +886-7-6282602  
Email: info@broadenal.com.tw



Customer		Insp Cert No.	QC23030118
P/O No.		Insp Cert Date	2023/3/21
Part No.	BN3-SDH5F1238C3N	Batch No.	
Description	12-24 x 38mm, Hex Flange Head Self-drilling Screw, No.5 Point, Silver Grey Ruspert 1000hrs, Green Line EPDM Washer, Head Mark: BN3, Drawing: BN3-SDH5F1238C3		
Technical Diagram			

No	Inspect Item	Standard	Unit	Measured											
				1	2	3	4	5	6	7	8	9	10		
1	Across Corner	min 8.64	mm	8.97	8.98	8.98	8.95	8.93							
2	Across Flat	7.78-7.92	mm	7.87	7.90	7.89	7.86	7.91							
3	Washer Diameter	13.97-14.78	mm	14.24	14.45	14.30	14.26	14.34							
4	Total Head Height	5.08-5.92	mm	5.75	5.78	5.77	5.74	5.84							
5	Total Length	37.20-38.80	mm	38.02	38.07	38.15	38.00	38.05							
6	Pitch	1.06	mm	1.06	1.06	1.06	1.06	1.06							
7	Major Diameter	5.29-5.48	mm	5.42	5.42	5.45	5.43	5.42							
8	Drill Point Length	17.00-18.00	mm	17.74	17.92	17.36	17.60	17.93							
9	Drill Point Width	4.90-5.00	mm	4.97	4.98	4.95	4.98	4.99							
10	Outer Diameter(EPDM)	10.70-11.30	mm	11.06	10.96	11.07	11.52	11.58							
11	EPDM Thickness	2.40-3.00	mm	2.64	2.59	2.64	2.68	2.71							
12	Surface Hardness(HV)	min 560	HV	602.00	617.00	609.00	602.00	610.00							
13	Core Hardness(HV)	max 425	HV	397.00	399.00	390.00	403.00	406.00							
14	Torsional Strength(N.m)	min 10.9	N.m	16.14	16.72	16.08	16.84	16.30							
15	Drilling Test 1 (25kg 1800rpm 12mm)	max 25.0	Sec	11.36	11.69	9.57	12.35	12.16	16.48	10.78	10.66	16.23	13.27		

Inspection Results	<b>OK</b>	Inspected	00120	Approved	
		Date	2023/3/21	Date	



Phone: +886-7-6282702  
Fax: +886-7-6282602  
Email: info@broadenal.com.tw



Customer		Insp Cert No.	QC23030028
P/O No.		Insp Cert Date	2023/3/3
Part No.	BN3-SDH5F1250C3N	Batch No.	

Description: 12-24 x 50mm, Hex Flange Head Self-drilling Screw, No.5 Point, Silver Grey Ruspert 1000hrs, Green Line EPDM Washer, Head Mark: BN3, Drawing: BDN-SDH5F1250C3

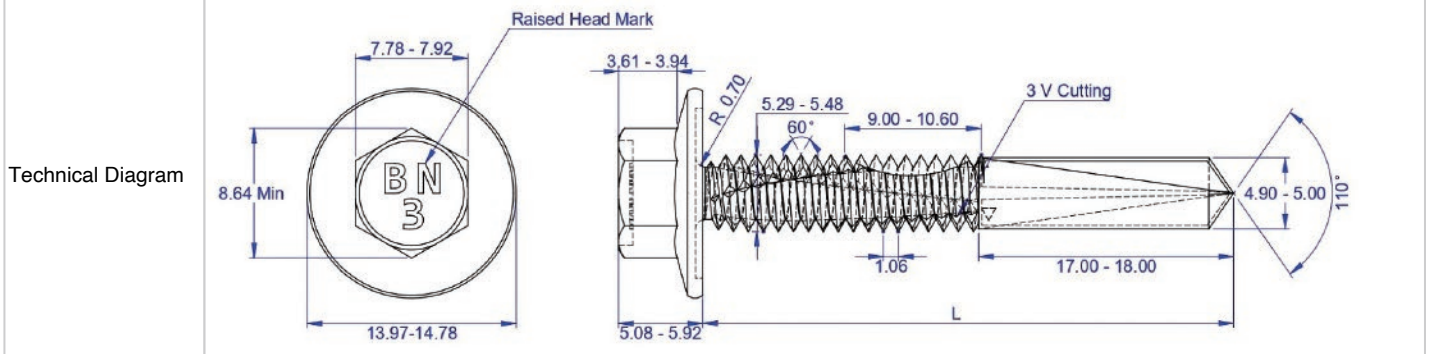

No	Inspect Item	Standard	Unit	Measured											
				1	2	3	4	5	6	7	8	9	10		
1	Across Corner	min 8.64	mm	8.99	9.00	8.98	9.01	9.00							
2	Across Flat	7.78-7.92	mm	7.88	7.88	7.86	7.87	7.86							
3	Washer Diameter	13.97-14.78	mm	14.42	14.41	14.39	14.44	14.41							
4	Total Head Height	5.08-5.92	mm	5.91	5.87	5.88	5.86	5.87							
5	Total Length	49.20-50.80	mm	49.96	49.27	49.66	50.05	50.01							
6	Pitch	1.06	mm	1.06	1.06	1.06	1.06	1.06							
7	Major Diameter	5.29-5.48	mm	5.42	5.42	5.42	5.43	5.44							
8	Drill Point Length	17.00-18.00	mm	17.89	17.44	17.53	17.27	17.55							
9	Drill Point Width	4.90-5.00	mm	4.91	4.93	4.92	4.94	4.95							
10	Outer Diameter(EPDM)	10.70-11.30	mm	11.01	11.03	10.98	10.96	11.00							
11	EPDM Thickness	2.40-3.00	mm	2.52	2.54	2.61	2.60	2.54							
12	Surface Hardness(HV)	min 560	HV	640.00	636.00	629.00	635.00	637.00							
13	Core Hardness(HV)	max 425	HV	393.00	395.00	396.00	397.00	389.00							
14	Torsional Strength(N.m)	min 10.9	N.m	16.31	16.34	16.89	16.98	16.66							
15	Drilling Test 1 (25kg 1800rpm 12mm)	max 25.0	Sec	11.47	11.20	9.92	9.87	10.25	10.53	14.10	10.48	9.41	14.50		

Inspection Results	<b>OK</b>	Inspected	00045	Approved	
		Date	2023/3/3	Date	

Phone: +886-7-6282702  
Fax: +886-7-6282602  
Email: info@broadenal.com.tw



Customer		Insp Cert No.	QC23030187
P/O No.		Insp Cert Date	2023/3/30
Part No.	BN3-SDHST1019C3N	Batch No.	
Description	10-16 x 19mm, Hex Flange Head Needle Point Screw, Silver Grey Ruspert 1000hrs, Green Line EPDM Washer, Head Mark: BN3		
Technical Diagram			

No	Inspect Item	Standard	Unit	Measured											
				1	2	3	4	5	6	7	8	9	10		
1	Across Corner	min 8.64	mm	8.97	8.96	8.91	8.95	8.94							
2	Across Flat	7.78-7.92	mm	7.84	7.84	7.86	7.85	7.86							
3	Washer Diameter	10.67-11.43	mm	10.97	10.95	10.92	10.99	10.94							
4	Total Head Height	4.32-4.83	mm	4.58	4.54	4.61	4.56	4.56							
5	Total Length	18.20-19.00	mm	18.91	18.67	18.72	18.96	18.82							
6	Pitch	1.58	mm	1.58	1.58	1.58	1.58	1.58							
7	Major Diameter (Twinfast Single Lead)	4.72-4.90	mm	4.77	4.77	4.76	4.76	4.80							
8	Outer Diameter(EPDM)	9.20-9.80	mm	9.35	9.42	9.39	9.40	9.38							
9	EPDM Thickness	2.40-3.00	mm	2.56	2.58	2.61	2.57	2.64							
10	Surface Hardness(HV)	min 450	HV	551.00	535.00	557.00	543.00	561.00							
11	Core Hardness(HV)	max 400	HV	391.00	386.00	393.00	389.00	394.00							
12	Torsional Strength(N.m)	min 6.5	N.m	9.75	9.26	9.43	9.04	8.72							
13	Drilling Test 1 (20kg 2500rpm 1mm)	max 2.0	Sec	0.57	0.36	0.37	0.35	0.39	0.37	0.81	0.36	0.31	0.39		

Inspection Results	<b>OK</b>	Inspected	00120	Approved	
		Date	2023/3/30	Date	

Phone: +886-7-6282702  
Fax: +886-7-6282602  
Email: info@broadenal.com.tw



Customer		Insp Cert No.	QC23020162
P/O No.		Insp Cert Date	2023/2/15
Part No.	BDN-SDHC1520C3N	Batch No.	
Description	15-15 x 20mm, Hex Flange Head Self-drilling Screw, Reduced Point, Silver Grey Ruspert 1000hrs, Green Line EPDM Washer, Head Mark: BN3, Drawing: BDN-SDHC1520C3		
Technical Diagram			

No	Inspect Item	Standard	Unit	Measured											
				1	2	3	4	5	6	7	8	9	10		
1	Across Corner	min 8.64	mm	8.86	8.85	8.80	8.84	8.82							
2	Across Flat	7.78-7.92	mm	7.88	7.88	7.89	7.86	7.90							
3	Washer Diameter	13.97-14.78	mm	14.28	14.22	14.35	14.29	14.37							
4	Total Head Height	5.92-6.30	mm	6.16	6.22	6.18	6.21	6.20							
5	Total Length	19.60-20.40	mm	19.74	19.96	19.82	20.07	19.96							
6	Pitch	1.69	mm	1.69	1.69	1.69	1.69	1.69							
7	Major Diameter (10°+30° asymmetric thread)	6.28-6.43	mm	6.36	6.42	6.42	6.40	6.38							
8	Drill Point Length	5.00-6.50	mm	6.25	6.15	6.12	6.20	6.17							
9	Drill Point Width	4.06-4.21	mm	4.20	4.19	4.21	4.19	4.20							
10	Outer Diameter(EPDM)	10.70-11.30	mm	10.73	10.97	10.74	10.86	10.98							
11	EPDM Thickness	2.40-3.00	mm	2.68	2.72	2.74	2.65	2.70							
12	Surface Hardness(HV)	min 560	HV	596.00	584.00	585.00	590.00	592.00							
13	Core Hardness(HV)	max 425	HV	411.00	410.00	416.00	412.00	413.00							
14	Torsional Strength(N.m)	min 14.0	N.m	23.32	23.26	22.60	22.46	22.31							
15	Drilling Test 1 (27kg 2500rpm 1.05+1.05mm)	max 3.0	Sec	0.38	0.45	0.38	0.39	0.45	0.57	0.43	0.51	0.34	0.51		

Inspection Results	<b>OK</b>	Inspected	00120	Approved	
		Date	2023/2/15	Date	



# Framing Fasteners

SDHCF1220C3 12-14 x 20mm

# BDN FASTENERS

## TEST CERTIFICATES - IN HOUSE

Phone: +886-7-6282702  
Fax: +886-7-6282602  
Email: info@broadenal.com.tw



Customer		Insp Cert No.	QC23010171
P/O No.		Insp Cert Date	2023/1/17
Part No.	BN3-SDHCF1220C3	Batch No.	

Description: 12-14 x 20mm, Hex Flange Head Self-drilling Screw, Dual-Edge Point, Silver Grey Ruspert 1000hrs, Head Mark: BN3, Drawing: BN3-SDHCF1220C3

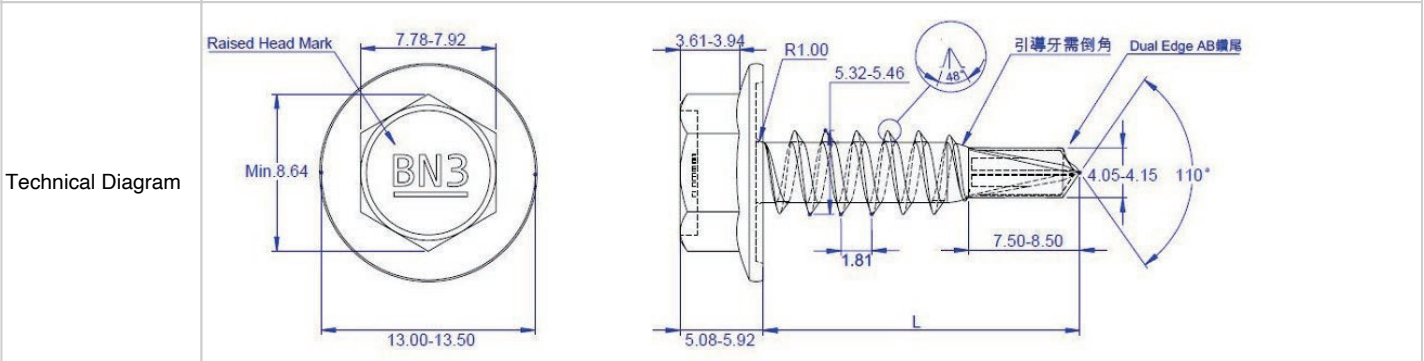

No	Inspect Item	Standard	Unit	Measured											
				1	2	3	4	5	6	7	8	9	10		
1	Across Corner	min 8.64	mm	8.91	8.95	8.90	8.97	8.96							
2	Across Flat	7.78-7.92	mm	7.82	7.85	7.82	7.83	7.85							
3	Washer Diameter	13.00-13.50	mm	13.30	13.32	13.33	13.35	13.40							
4	Total Head Height	5.08-5.92	mm	5.58	5.52	5.57	5.56	5.56							
5	Total Length	19.00-20.00	mm	19.74	19.77	19.60	19.73	19.76							
6	Major Diameter	5.32-5.46	mm	5.43	5.45	5.41	5.41	5.41							
7	Pitch	1.81	mm	1.81	1.81	1.81	1.81	1.81							
8	Drill Point Length	7.50-8.50	mm	8.24	8.01	7.86	7.81	8.15							
9	Drill Point Width	4.05-4.15	mm	4.09	4.11	4.10	4.10	4.09							
10	Surface Hardness(HV)	min 560	HV	599.70	591.40	607.90	591.40	612.20							
11	Core Hardness(HV)	max 425	HV	397.10	393.90	397.80	414.70	406.80							
12	Torsional Strength(N.m)	min 10.0	N.m	11.72	12.36	12.31	11.96	11.87							
13	Drilling Test 1 (20kg 1800rpm 3.0mm)	max 5.0	Sec	2.03	2.31	2.34	2.56	2.04	2.82	2.67	2.56	3.48	2.91		

Inspection Results	<b>OK</b>	Inspected	00067	Approved	
		Date	2023/1/17	Date	



**Framing Fasteners**

SDHTSF0816C3 M8.0-2.12 x 16mm

**BDN FASTENERS**

**TEST CERTIFICATES - IN HOUSE**

Phone: +886-7-6282702  
 Fax: +886-7-6282602  
 Email: info@broadenal.com.tw



Customer		Insp Cert No.	QC23020082
P/O No.		Insp Cert Date	2023/2/15
Part No.	BN3-SDHTSF0816C3	Batch No.	

Description: M8.0-2.12 x 16mm, Hex Flange Head Taptite Screw, Silver Grey Ruspert 1000hrs, Head Mark: BN3, Drawing: BN3-SDHTSF0816C3

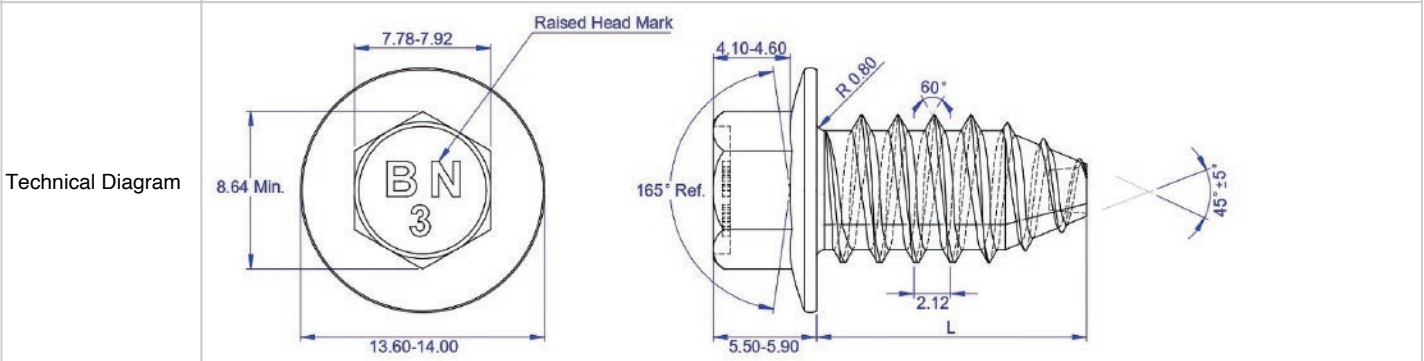

No	Inspect Item	Standard	Unit	Measured										
				1	2	3	4	5	6	7	8	9	10	
1	Across Corner	min 8.64	mm	9.00	9.00	9.03	9.03	9.05						
2	Across Flat	7.78-7.92	mm	7.88	7.89	7.89	7.90	7.91						
3	Washer Diameter	13.60-14.00	mm	13.72	13.82	13.69	13.77	13.93						
4	Total Head Height	5.50-5.90	mm	5.80	5.80	5.79	5.79	5.81						
5	Total Length	15.11-16.63	mm	16.09	16.14	16.18	16.58	16.43						
6	Diameter of Circumscribing Circle	8.51-8.76	mm	8.51	8.53	8.53	8.56	8.54						
7	Measurement Across Center	8.25-8.51	mm	8.40	8.43	8.37	8.41	8.38						
8	Pitch	2.12	mm	2.12	2.12	2.12	2.12	2.12						
9	Surface Hardness(HRC)	min 45	HRC	51.40	47.30	51.30	50.90	51.90						
10	Core Hardness(HRC)	28-38	HRC	34.20	35.70	34.90	35.20	35.10						
11	Torsional Strength(N.m)	min 25.0	N.m	31.00	30.00	35.00	31.00	33.00						

Inspection Results	<b>OK</b>
--------------------	-----------

Inspected	00120	Approved	
Date	2023/2/15	Date	



**Framing Fasteners**

SDFHSF0622C3 M6.0-1.00 x 22mm

**BDN FASTENERS**

**TEST CERTIFICATES - IN HOUSE**

Phone: +886-7-6282702  
 Fax: +886-7-6282602  
 Email: info@broadenal.com.tw



Customer		Insp Cert No.	QC23010012
P/O No.		Insp Cert Date	2023/1/5
Part No.	BN3-SDFHSF0622C3	Batch No.	

Description: M6.0-1.00 x 22mm, Flat Head Self-drilling Screw, Fine Thread, Silver Grey Ruspert 1000hrs, Head Mark: BN3, Drawing: BN3-SDFHSF0622C3

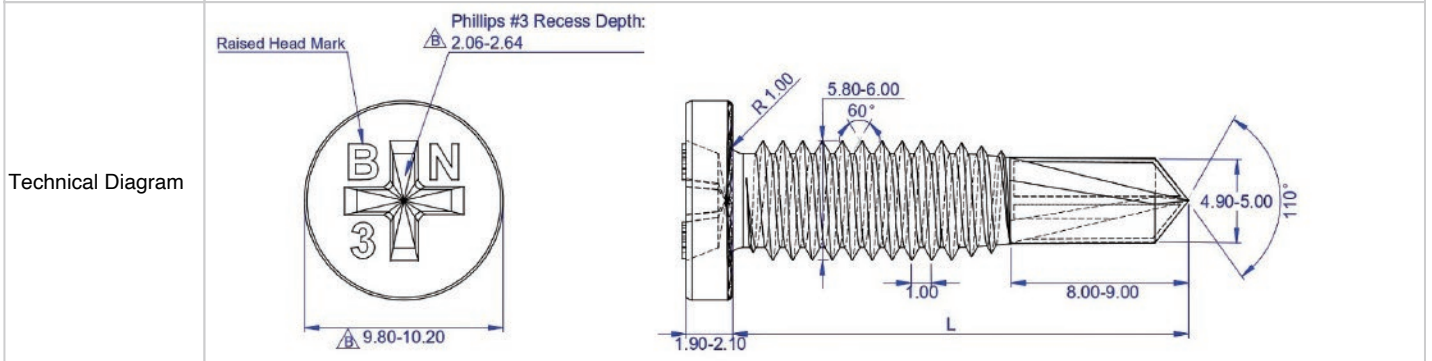

No	Inspect Item	Standard	Unit	Measured											
				1	2	3	4	5	6	7	8	9	10		
1	Head Diameter (18T serr.)	9.80-10.20	mm	10.03	10.01	10.05	10.07	10.04							
2	Total Head Height	1.90-2.10	mm	2.04	2.03	2.06	2.05	2.01							
3	Drive Recess	2.06-2.64	mm	2.34	2.29	2.40	2.34	2.41							
4	Total Length	21.50-22.50	mm	21.97	21.94	21.84	21.97	21.87							
5	Major Diameter	5.80-6.00	mm	5.97	5.98	5.97	5.97	5.97							
6	Pitch	1.00	mm	1.00	1.00	1.00	1.00	1.00							
7	Drill Point Length	8.00-9.00	mm	8.52	8.44	8.81	8.48	8.45							
8	Drill Point Width	4.90-5.00	mm	4.94	4.94	4.93	4.95	4.94							
9	Surface Hardness(HV)	min 560	HV	597.00	623.00	608.00	600.00	608.00							
10	Core Hardness(HV)	max 425	HV	420.00	408.00	415.00	412.00	417.00							
11	Torsional Strength(N.m)	min 12.0	N.m	18.57	19.19	18.52	17.86	17.94							
12	Drilling Test 1 (25kg 1800rpm 3.0mm)	max 5.0	Sec	2.05	2.39	2.27	2.61	2.55	2.51	2.88	2.54	2.29	2.33		

Inspection Results	<b>OK</b>
--------------------	-----------

Inspected	00045	Approved	
Date	2023/1/5	Date	

Phone: +886-7-6282702  
Fax: +886-7-6282602  
Email: info@broadenal.com.tw



Customer		Insp Cert No.	QC23010062
P/O No.		Insp Cert Date	2023/1/12
Part No.	BDN-T17H1020C3N	Batch No.	
Description	10-12 x 20mm, Hex Flange Head Type17 Self-Tapping Screw, Silver Grey Ruspert 1000hrs, Green Line EPDM Washer, Head Mark: BN3, Drawing: BDN-T17H1020C3		

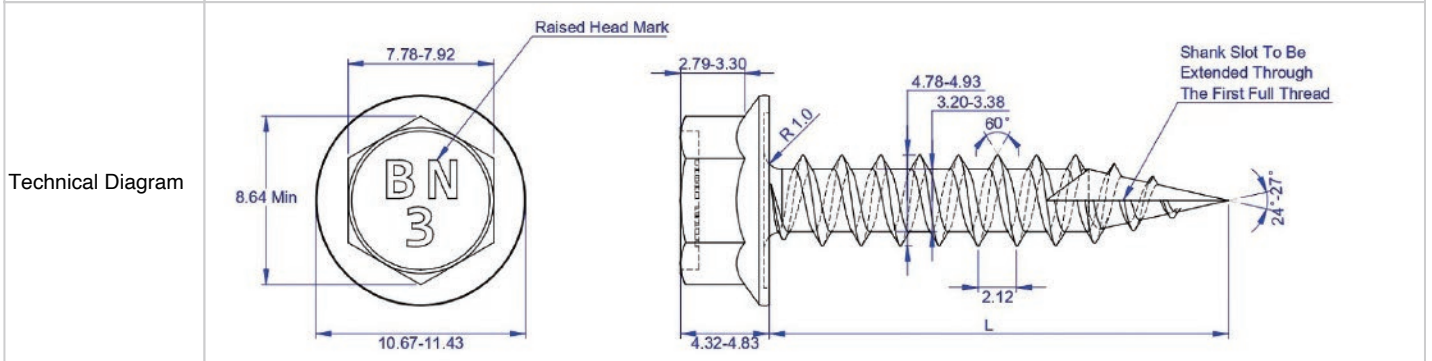

No	Inspect Item	Standard	Unit	Measured										
				1	2	3	4	5	6	7	8	9	10	
1	Across Corner	min 8.64	mm	8.98	9.02	8.98	9.04	8.99						
2	Across Flat	7.78-7.92	mm	7.87	7.91	7.87	7.88	7.90						
3	Washer Diameter	10.67-11.43	mm	10.98	11.04	11.04	11.09	11.03						
4	Total Head Height	4.32-4.83	mm	4.65	4.64	4.62	4.63	4.65						
5	Total Length	19.20-20.00	mm	19.52	19.82	19.73	19.59	19.56						
6	Pitch	2.12	mm	2.12	2.12	2.12	2.12	2.12						
7	Major Diameter	4.78-4.93	mm	4.88	4.87	4.86	4.85	4.88						
8	Outer Diameter(EPDM)	9.20-9.80	mm	9.43	9.43	9.42	9.42	9.38						
9	EPDM Thickness	2.40-3.00	mm	2.59	2.48	2.57	2.52	2.53						
10	Surface Hardness(HV)	min 450	HV	551.00	535.00	559.00	543.00	562.00						
11	Core Hardness(HV)	max 400	HV	391.00	385.00	393.00	389.00	392.00						
12	Torsional Strength(N.m)	min 5.4	N.m	8.15	7.87	8.02	8.20	7.82						

Inspection Results	<b>OK</b>
--------------------	-----------

Inspected	00120	Approved	
Date	2023/1/12	Date	



Fax: +886-7-6282602  
Email: info@broadenal.com.tw

Customer		Insp Cert No.	QC23030135
P/O No.		Insp Cert Date	2023/3/15
Part No.	BDN-T17HCG1250C3N	Batch No.	
Description	12-11 x 50mm, Hex Flange Head Type17 Screw, Double Thread, Silver Grey Ruspert 1000hrs, Green Line EPDM Washer, Head Mark: BN3, Drawing: BDN-T17HCG1250C3		
Technical Diagram			

No	Inspect Item	Standard	Unit	Measured										
				1	2	3	4	5	6	7	8	9	10	
1	Across Corner	min 8.64	mm	8.96	8.97	8.97	8.98	8.96						
2	Across Flat	7.78-7.92	mm	7.81	7.82	7.81	7.79	7.82						
3	Washer Diameter	13.97-14.78	mm	14.41	14.38	14.36	14.35	14.31						
4	Total Head Height	5.08-5.92	mm	5.79	5.76	5.71	5.76	5.75						
5	Total Length	48.50-50.00	mm	49.18	49.24	49.07	49.22	49.06						
6	Shankguard Diameter	4.88-5.20	mm	5.07	5.11	5.07	5.05	5.07						
7	Upper Thread Major Diameter	6.30-6.45	mm	6.34	6.35	6.35	6.36	6.34						
8	Lower Thread Major Diameter	5.46-5.74	mm	5.54	5.53	5.53	5.54	5.54						
9	Upper Thread Length	REF 8.50	mm	8.82	8.95	8.89	9.02	8.91						
10	Lower Thread Length	34.00-37.00	mm	34.23	34.35	34.16	34.36	34.12						
11	Lower Thread Pitch	2.31	mm	2.31	2.31	2.31	2.31	2.31						
12	Outer Diameter(EPDM)	10.70-11.30	mm	11.11	11.23	11.03	11.05	11.07						
13	EPDM Thickness	2.40-3.00	mm	2.66	2.65	2.71	2.68	2.75						
14	Surface Hardness(HV)	min 450	HV	562.00	557.00	549.00	551.00	545.00						
15	Core Hardness(HV)	max 400	HV	395.00	387.00	393.00	390.00	394.00						
16	Torsional Strength(N.m)	min 9.4	N.m	13.34	14.52	13.14	12.91	13.67						

Inspection Results	<b>OK</b>
--------------------	-----------

Inspected	00096	Approved	
Date	2023/3/15	Date	



Phone: +886-7-6282702  
Fax: +886-7-6282602  
Email: info@broadenal.com.tw



Customer		Insp Cert No.	QC23030045
P/O No.		Insp Cert Date	2023/3/9
Part No.	BDN-T17HCG1265C3N	Batch No.	
Description	12-11 x 65mm, Hex Flange Head Type17 Screw, Double Thread, Silver Grey Ruspert 1000hrs, Green Line EPDM Washer, Head Mark: BN3, Drawing: BDN-T17HCG1265C3		

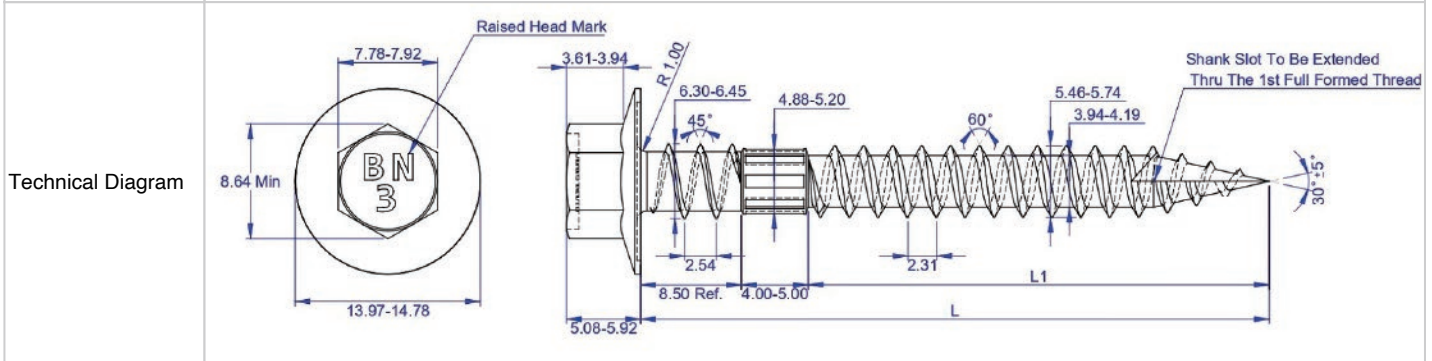

No	Inspect Item	Standard	Unit	Measured											
				1	2	3	4	5	6	7	8	9	10		
1	Across Corner	min 8.64	mm	8.99	9.00	9.00	9.00	8.99							
2	Across Flat	7.78-7.92	mm	7.89	7.90	7.89	7.89	7.89							
3	Washer Diameter	13.97-14.78	mm	14.14	14.35	14.38	14.51	14.25							
4	Total Head Height	5.08-5.92	mm	5.77	5.73	5.73	5.73	5.74							
5	Total Length	63.50-65.00	mm	63.86	63.87	63.94	63.74	63.82							
6	Shankguard Diameter	4.88-5.20	mm	4.95	4.93	4.93	4.98	4.98							
7	Upper Thread Major Diameter	6.30-6.45	mm	6.38	6.34	6.38	6.37	6.37							
8	Lower Thread Major Diameter	5.46-5.74	mm	5.61	5.60	5.60	5.62	5.59							
9	Upper Thread Length	REF 8.50	mm	8.99	8.84	8.90	8.93	8.84							
10	Lower Thread Length	44.00-47.00	mm	44.39	44.38	44.35	44.37	44.24							
11	Lower Thread Pitch	2.31	mm	2.33	2.33	2.33	2.33	2.33							
12	Outer Diameter(EPDM)	10.70-11.30	mm	10.94	11.19	11.15	11.19	11.00							
13	EPDM Thickness	2.40-3.00	mm	2.63	2.64	2.66	2.68	2.71							
14	Surface Hardness(HV)	min 450	HV	595.00	588.00	599.00	597.00	581.00							
15	Core Hardness(HV)	max 400	HV	380.00	389.00	372.00	377.00	371.00							
16	Torsional Strength(N.m)	min 9.4	N.m	12.52	12.41	12.69	11.96	12.50							

Inspection Results	<b>OK</b>
--------------------	-----------

Inspected	00045	Approved	
Date	2023/3/9	Date	

Phone: +886-7-6282702  
Fax: +886-7-6282602  
Email: info@broadenal.com.tw



Customer		Insp Cert No.	QC23010112
P/O No.		Insp Cert Date	2023/1/5
Part No.	BDN-T17HCG1275C3N	Batch No.	
Description	12-11 x 75mm, Hex Flange Head Type17 Screw, Double Thread, Silver Grey Ruspert 1000hrs, Green Line EPDM Washer, Head Mark: BN3, Drawing: BDN-T17HCG1275C3		
Technical Diagram			

No	Inspect Item	Standard	Unit	Measured											
				1	2	3	4	5	6	7	8	9	10		
1	Across Corner	min 8.64	mm	8.88	8.91	8.90	8.90	8.88							
2	Across Flat	7.78-7.92	mm	7.82	7.82	7.81	7.82	7.82							
3	Washer Diameter	13.97-14.78	mm	14.14	14.35	14.36	14.23	14.38							
4	Total Head Height	5.08-5.92	mm	5.57	5.56	5.61	5.57	5.61							
5	Total Length	73.50-75.00	mm	73.75	73.87	73.93	74.31	74.03							
6	Shankguard Diameter	4.88-5.20	mm	4.96	4.95	4.93	5.03	5.02							
7	Shankguard Length	4.00-5.00	mm	4.58	4.36	4.51	4.55	4.37							
8	Upper Thread Major Diameter	6.30-6.45	mm	6.37	6.36	6.35	6.37	6.35							
9	Lower Thread Major Diameter	5.46-5.74	mm	5.64	5.66	5.66	5.66	5.67							
10	Upper Thread Length	REF 8.50	mm	8.89	8.69	8.64	8.72	8.83							
11	Lower Thread Length	44.00-47.00	mm	45.54	45.49	45.45	45.50	45.78							
12	Lower Thread Pitch	2.31	mm	2.31	2.31	2.31	2.31	2.31							
13	Surface Hardness(HV)	min 450	HV	587.00	592.00	588.00	596.00	591.00							
14	Core Hardness(HV)	max 400	HV	388.00	391.00	386.00	393.00	389.00							
15	Torsional Strength(N.m)	min 9.4	N.m	13.22	13.59	13.37	12.60	12.39							
16	Outer Diameter(EPDM)	10.70-11.30	mm	10.84	11.11	11.15	11.03	11.18							
17	EPDM Thickness	2.40-3.00	mm	2.69	2.68	2.63	2.66	2.67							

Inspection Results	<b>OK</b>
--------------------	-----------

Inspected	00067	Approved	
Date	2023/1/5	Date	

Phone: +886-7-6282702  
Fax: +886-7-6282602  
Email: info@broadenal.com.tw



Customer		Insp Cert No.	QC23020013
P/O No.		Insp Cert Date	2023/2/13
Part No.	BDN-NPBF35025BP	Batch No.	

Description: M3.5 x 25mm, Bulge Head Drywall Screw, Twinfast Single Lead, Fine Thread, Black Phosphate

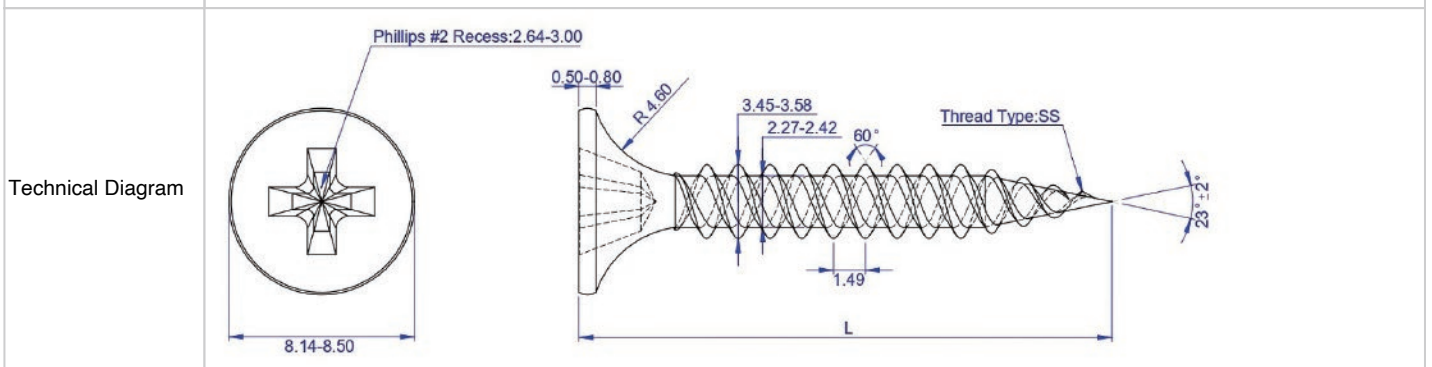

No	Inspect Item	Standard	Unit	Measured											
				1	2	3	4	5	6	7	8	9	10		
1	Head Diameter	8.14-8.50	mm	8.36	8.33	8.28	8.31	8.31							
2	Edge thickness	0.50-0.80	mm	0.76	0.64	0.64	0.80	0.74							
3	Drive Recess	2.64-3.00	mm	2.84	2.85	2.85	2.84	2.83							
4	Total Length	24.20-25.80	mm	25.00	24.74	25.04	25.15	25.18							
5	Major Diameter (Twinfast Single Lead)	3.45-3.58	mm	3.56	3.55	3.52	3.56	3.55							
6	Pitch	1.49	mm	1.49	1.49	1.49	1.49	1.49							
7	Surface Hardness(HV)	min 580	HV	665.00	653.00	649.00	657.00	645.00							
8	Torsional Strength(N.m)	min 2.8	N.m	4.08	3.78	3.94	3.94	4.14							
9	Drilling Test 1 (13.6kg 2500rpm 1.0mm)	max 3.5	Sec	1.44	1.18	1.49	0.52	0.46	0.70	1.27	1.06	0.73	1.03		

Inspection Results	<b>OK</b>	Inspected	00096	Approved	
		Date	2023/2/13	Date	

Phone: +886-7-6282702  
Fax: +886-7-6282602  
Email: info@broadenal.com.tw



Customer		Insp Cert No.	QC23020113
P/O No.		Insp Cert Date	2023/2/13
Part No.	BDN-NPBF35032BP	Batch No.	

Description: M3.5 x 32mm, Bulge Head Drywall Screw, Twinfast Single Lead, Fine Thread, Black Phosphate

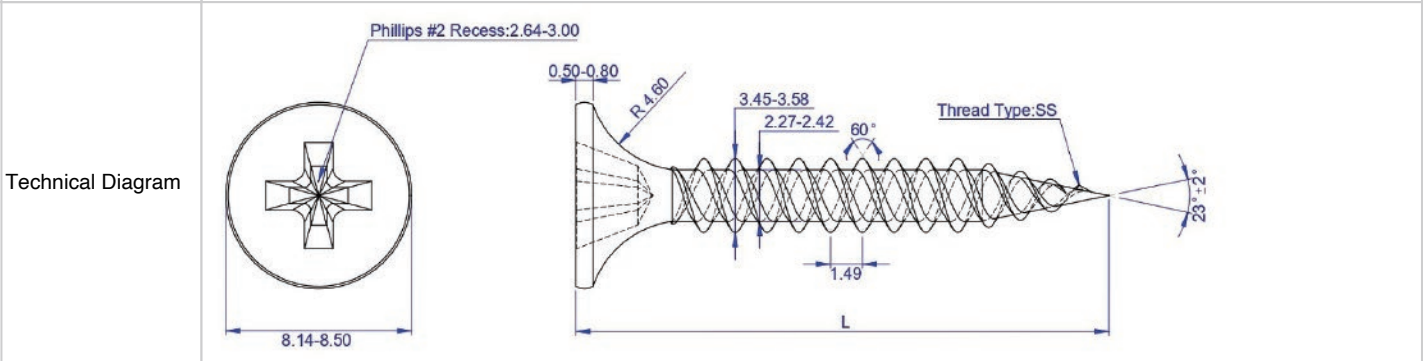

No	Inspect Item	Standard	Unit	Measured											
				1	2	3	4	5	6	7	8	9	10		
1	Head Diameter	8.14-8.50	mm	8.15	8.19	8.21	8.25	8.19							
2	Edge thickness	0.50-0.80	mm	0.79	0.77	0.79	0.80	0.80							
3	Drive Recess	2.64-3.00	mm	2.88	2.85	2.84	2.84	2.85							
4	Total Length	30.70-33.30	mm	31.18	31.68	31.36	31.48	31.52							
5	Major Diameter (Twinfast Single Lead)	3.45-3.58	mm	3.54	3.57	3.56	3.55	3.54							
6	Pitch	1.49	mm	1.48	1.48	1.48	1.48	1.48							
7	Surface Hardness(HV)	min 580	HV	671.00	665.00	686.00	678.00	634.00							
8	Torsional Strength(N.m)	min 2.8	N.m	3.59	3.66	3.79	3.64	3.71							
9	Drilling Test 1 (13.6kg 2500rpm 1.0mm)	max 3.5	Sec	0.55	0.41	0.36	0.84	0.57	0.60	0.47	0.68	0.66	0.58		

Inspection Results	<b>OK</b>	Inspected	00096	Approved	
		Date	2023/2/13	Date	



Fax: +886-7-6282602  
Email: info@broadenal.com.tw

Page 1 / 1

Customer		Insp Cert No.	QC23020114
P/O No.		Insp Cert Date	2023/2/13
Part No.	BDN-NPBC35032BP	Batch No.	

Description: M3.5 x 32mm, Bulge Head Drywall Screw, Coarse Thread, Black Phosphate

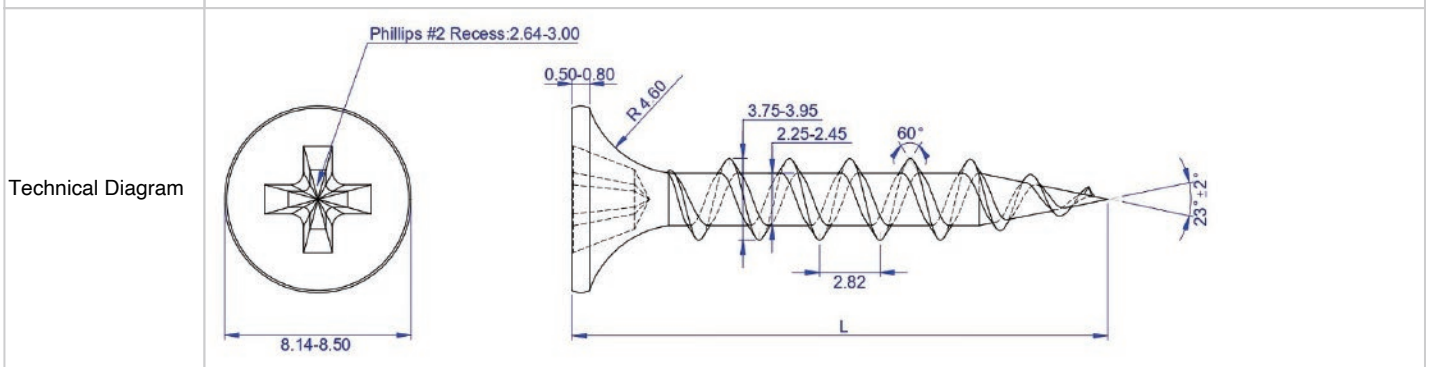

No	Inspect Item	Standard	Unit	Measured											
				1	2	3	4	5	6	7	8	9	10		
1	Head Diameter	8.14-8.50	mm	8.32	8.19	8.29	8.36	8.15							
2	Edge thickness	0.50-0.80	mm	0.76	0.80	0.71	0.77	0.75							
3	Drive Recess	2.64-3.00	mm	2.88	2.80	2.85	2.88	2.86							
4	Total Length	30.70-33.30	mm	31.08	31.50	31.36	31.86	31.45							
5	Major Diameter	3.75-3.95	mm	3.79	3.82	3.89	3.91	3.82							
6	Pitch	2.82	mm	2.82	2.82	2.82	2.82	2.82							
7	Surface Hardness(HV)	min 580	HV	705.00	657.00	641.00	691.00	662.00							
8	Torsional Strength(N.m)	min 2.8	N.m	3.35	3.65	3.37	3.61	3.58							

Inspection Results	<b>OK</b>
--------------------	-----------

Inspected	00096	Approved	
Date	2023/2/13	Date	



# TEST CERTIFICATES IN HOUSE

## **BDN FASTENERS® HEADQUARTER (TAIWAN)**

Broaden Worldwide Co., Ltd.

NO. 47-37, Jiahua Rd., Gangshan Dist., Kaohsiung City 820, Taiwan (R.O.C)

TEL: +886-7-6282702 | FAX: +886-7-6282601

E-mail: [info@bdfasteners.com](mailto:info@bdfasteners.com)

Website: [www.bdfasteners.com](http://www.bdfasteners.com)